



# NEWEL 3



## USER MANUAL

### REGULATION OF HYGROMETRY

Digitel reserves the right to modify the technical characteristics described without prior notice.

Non-contractual document

Digitel SA

All rights reserved

# 9. REGULATION OF HYGROMETRY

## 9.1. INTRODUCTION

It is assumed that the reader of this document will previously have read the chapter “1 Introduction to NEWEL3”. The latter describes all the basic concepts which are essential to an understanding of the present document, and of the concept of the NEWEL3 product range in general.

This manual describes the operation of modules for the **regulation of hygrometry**. In this case, parameter [r1] in the basic configuration will be programmed to 2.

## 9.2. GENERAL DESCRIPTION, BASIC CONNECTIONS

Connections will be completed in accordance with the circuit layout shown in **Figure 9.2.1**, **Figure 9.2.2** and **Figure 9.2.3**

0-10V :

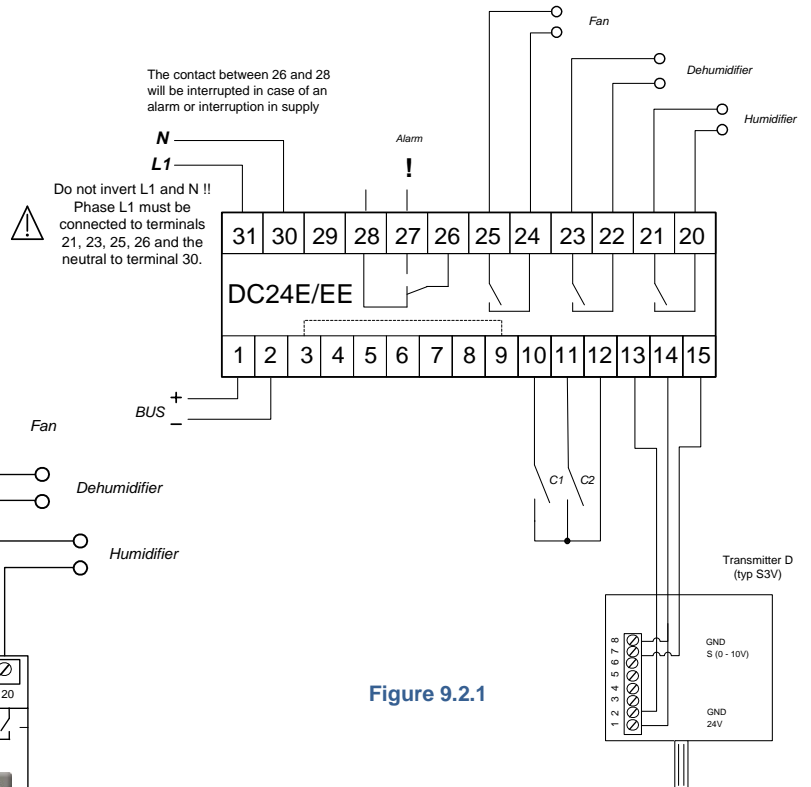

Figure 9.2.1

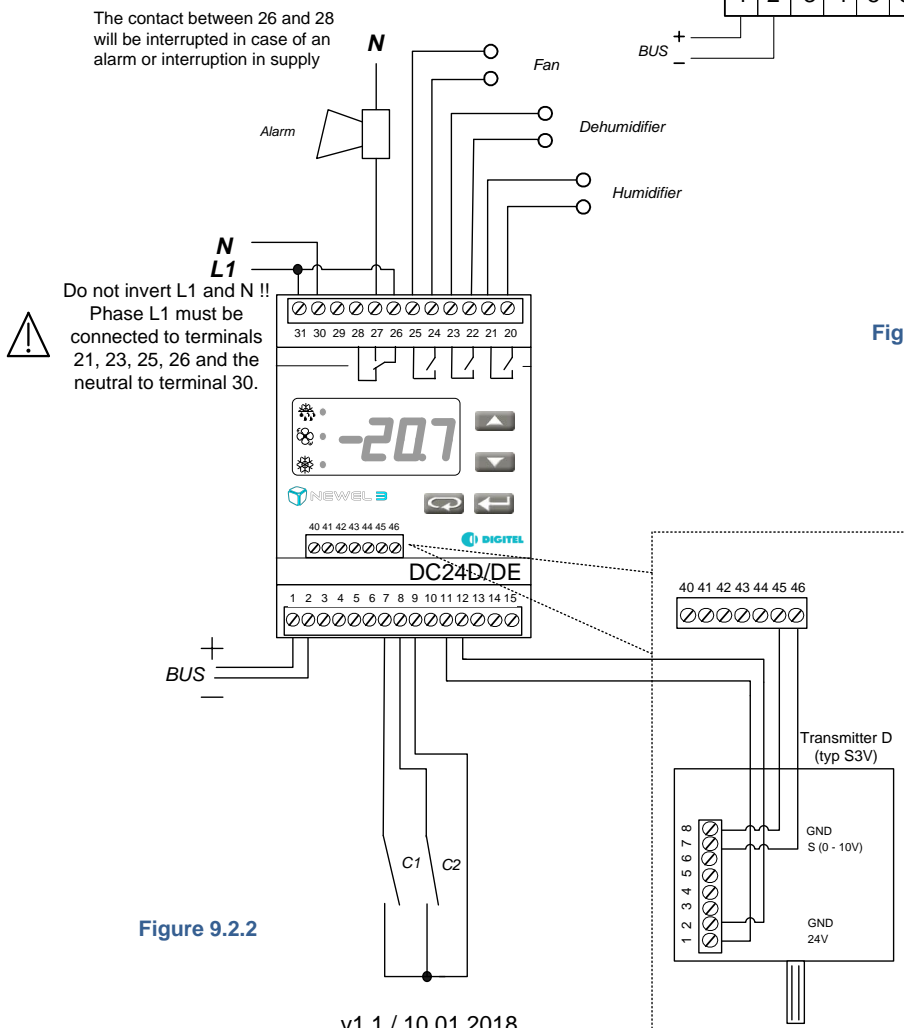

Figure 9.2.2

v1.1 / 10.01.2018

4-20mA :

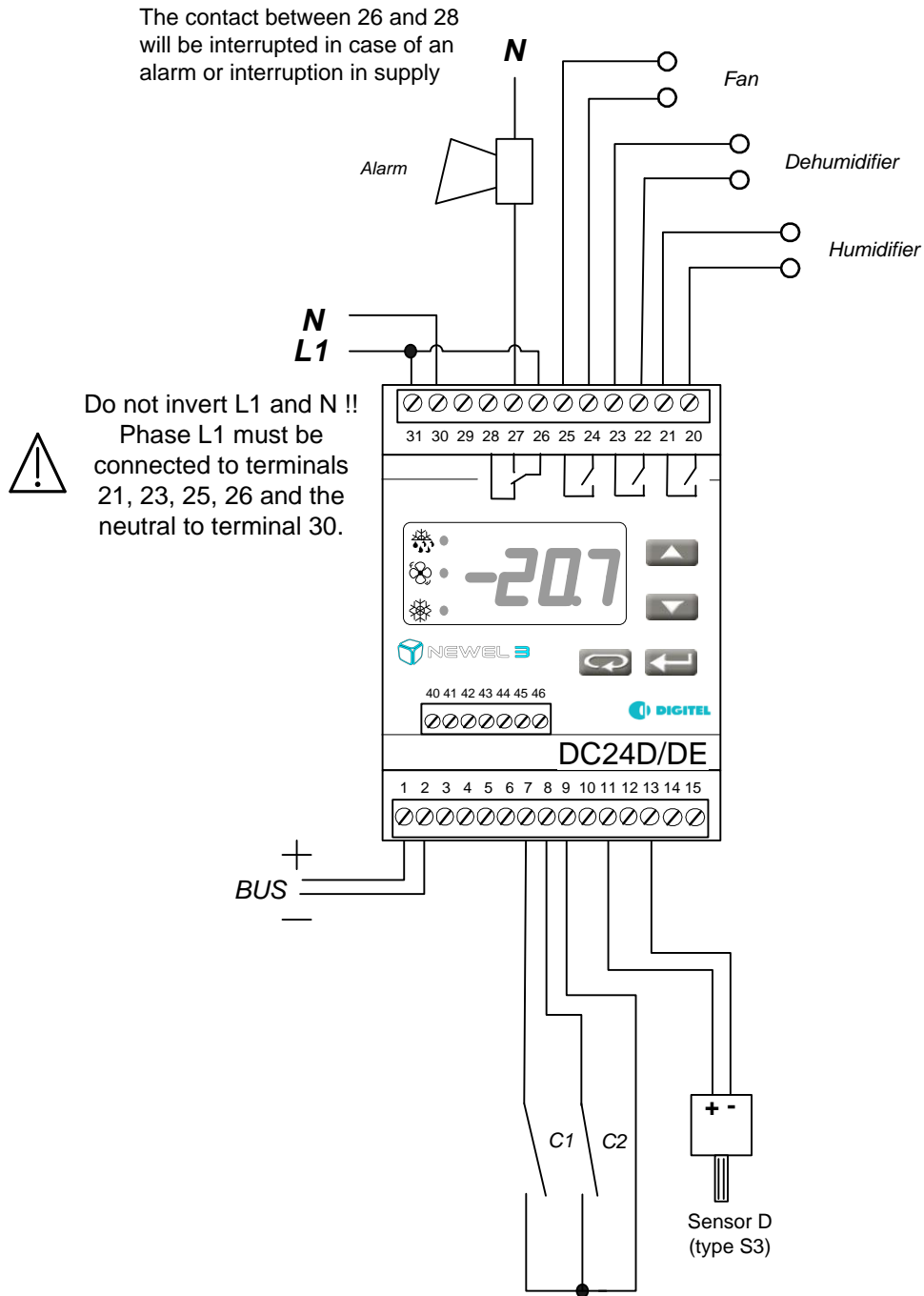

Figure 9.2.3

For the sensors of the last few schemas, the parameter “Sensor type” [o0] must be set on “0” for the 4-20mA sensors and on “1” for the 0-10V sensors

[o0] Sensor Type (*Settings menu*)

### 9.3. REGULATION WITH A LUMINOSITY SENSOR DI-LUM

The DI-LUM of the following figure is a luminosity sensor. Its measurement range must be set on 0 for the minimal value and on 100 for the maximal value. This way, the value will be displayed in kLux.

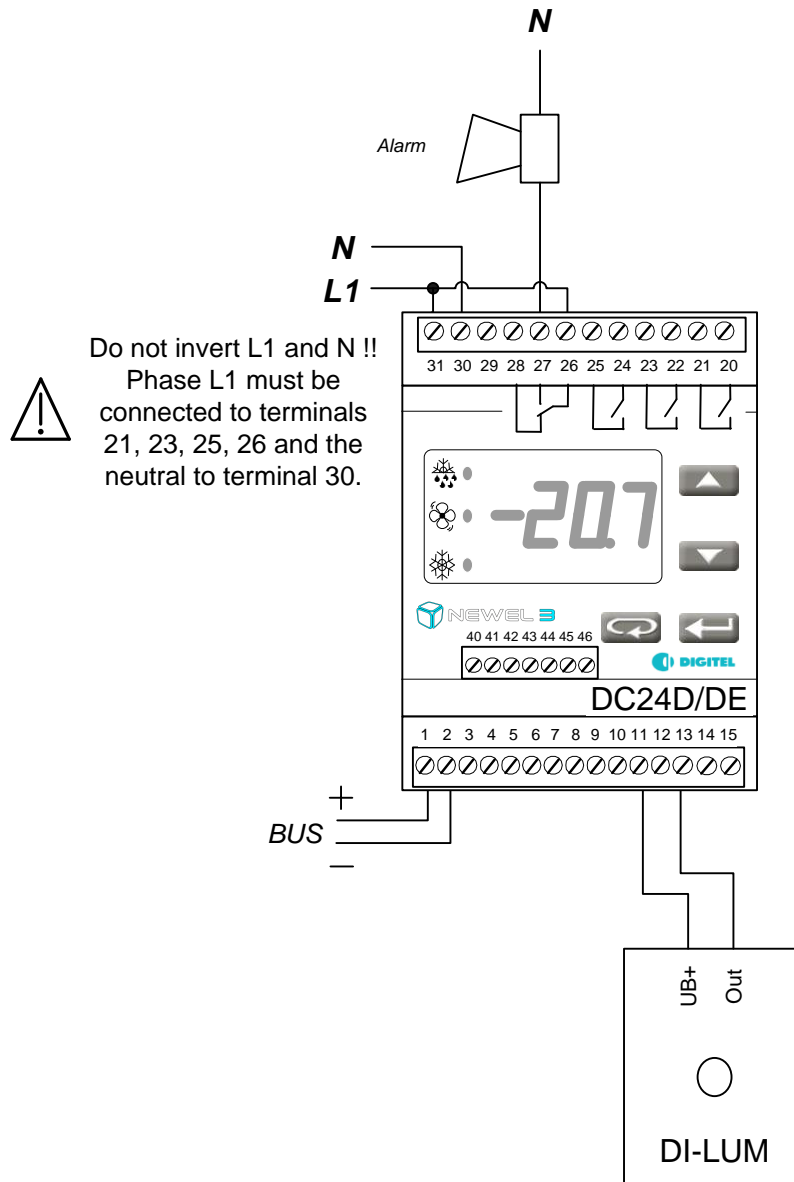

Figure 9.3.1

For this sensor, the parameter « sensor type » [o0] must be set on "0"

[o0] Sensor Type (*Settings menu*)

## 9.4. REGULATION OF HYGROMETRY

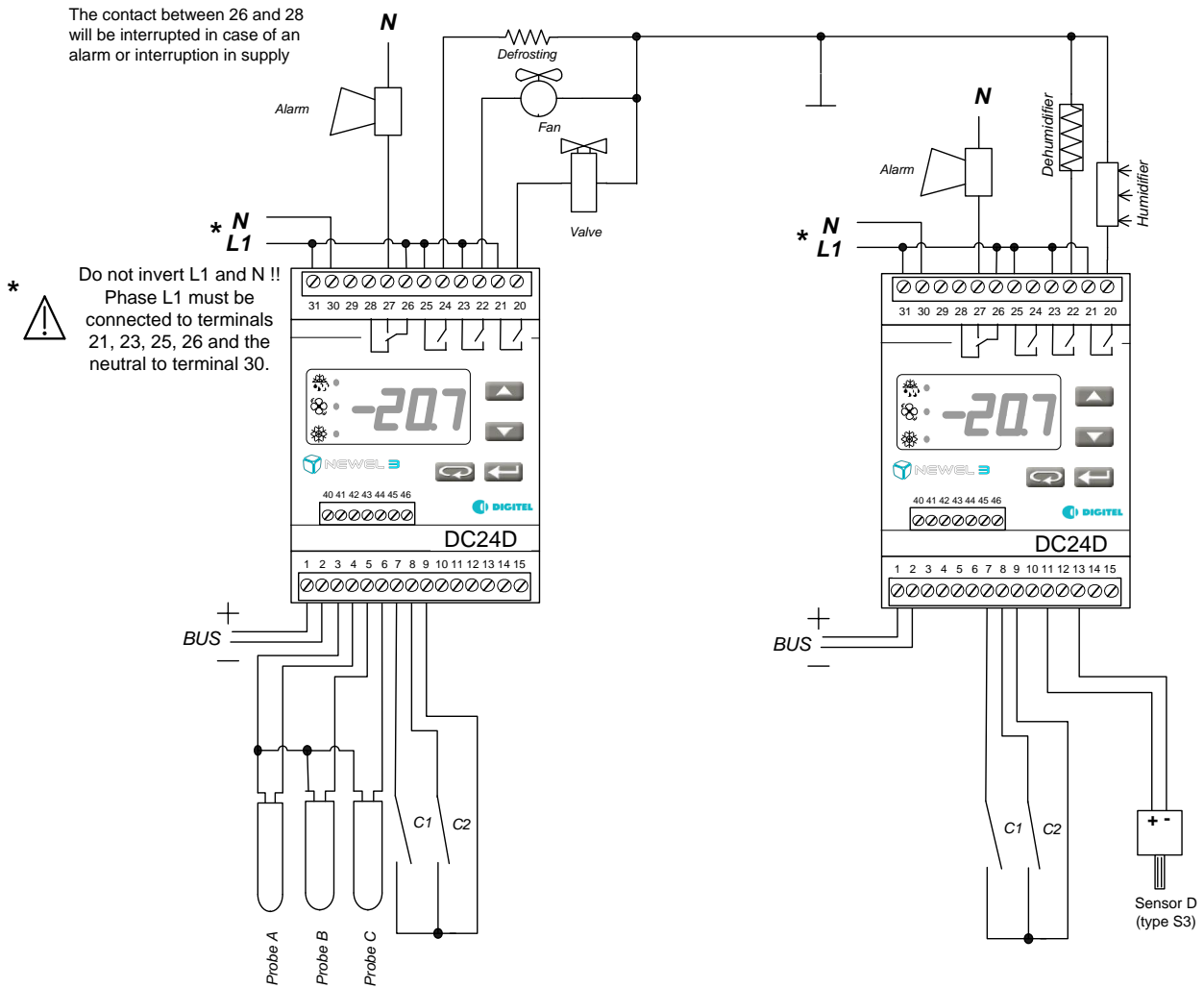

Figure 9.4.1

The operation of the hygrometry regulation function will be as follows:

If the measured humidity rises above  $[U1] + [U2]$ , the dehumidification relay will be activated. This relay will remain active until the humidity falls below  $[U1]$ .

If the humidity falls below  $[U1] - [U3] - [U4]$ , the humidifier relay will be activated. This relay will remain active until the humidity rises above  $[U1] - [U3]$ .

- 
- [U1]** Setpoint (Regulation menu)
  - [U2]** Delta for dehumidification (Regulation menu)
  - [U3]** Neutral zone (Regulation menu)
  - [U4]** Delta for humidification (Regulation menu)

This function is represented graphically in the diagram below.

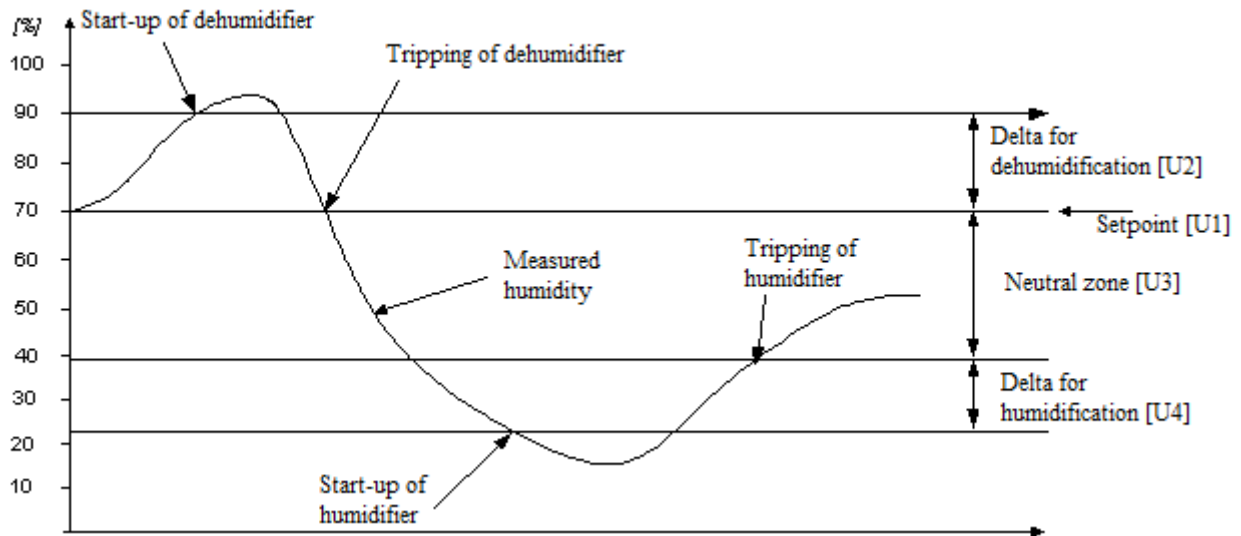

Figure 9.4.2

The regulation system is provided with a programmable alarm function (parameters [E1], [E2] and [E3]).

For the measure of the regulated value DC24D/DE modules can use 4-20mA or 0-10V sensors. The DC24E/EE can only use the 0-10V sensors.

The functions of contacts C1 and C2 will be programmable. These may function as alarm contacts, shutdown contacts or setpoint offset contacts (see Chapter 9.7 C1, C2 contacts).

## Other applications

The module can be easily adapted to other applications, e.g. the regulation of concentrations of oxygen, carbon dioxide, etc.

A sensor with a 4-20 mA or 0-10V (DC24D/DE) output will be required for this purpose, together with the adaptation of parameters [o1] and [o2].

---

<b>[E1]</b>	Lower alarm limit (Security menu)
<b>[E2]</b>	Upper alarm limit (Security menu)
<b>[E3]</b>	Alarm delay (Security menu)
<b>[o1]</b>	Range of measurement of sensor – Lower limit (Setting menu)
<b>[o2]</b>	Range of measurement of sensor – Upper limit (Setting menu)

---

## 9.5. SETPOINT OFFSET

The setpoint determined by the value of parameter **[U1]** may be temporarily offset by a positive or negative value which is programmable in parameter **[U5]**. This offset will be controlled by the clock function of the module within a given time interval, the start of which will be equal to the value of parameter **[U6]** and the end of which will be equal to the value of **[U7]**.

The same setpoint offset may be controlled by the closure of contacts C1 or C2, where the function of the latter is programmed to 4 (see parameters **[o4]** and **[o6]** in Chapter 9.7) or by the weekly schedule function (see Chapter 1.8.1).

The alarm limits programmed in **[E1]** and **[E2]** will be offset at the same time and by the same value as the setpoints.

## 9.6. ANALOGUE OUTPUT

This output is intended for the control of a DC01 module, which is provided with a 4-20 mA and 0-10V output – see Figure 9.6.1. This output will vary proportionally to the humidity value, between parameters **[b2]** and **[b3]**.

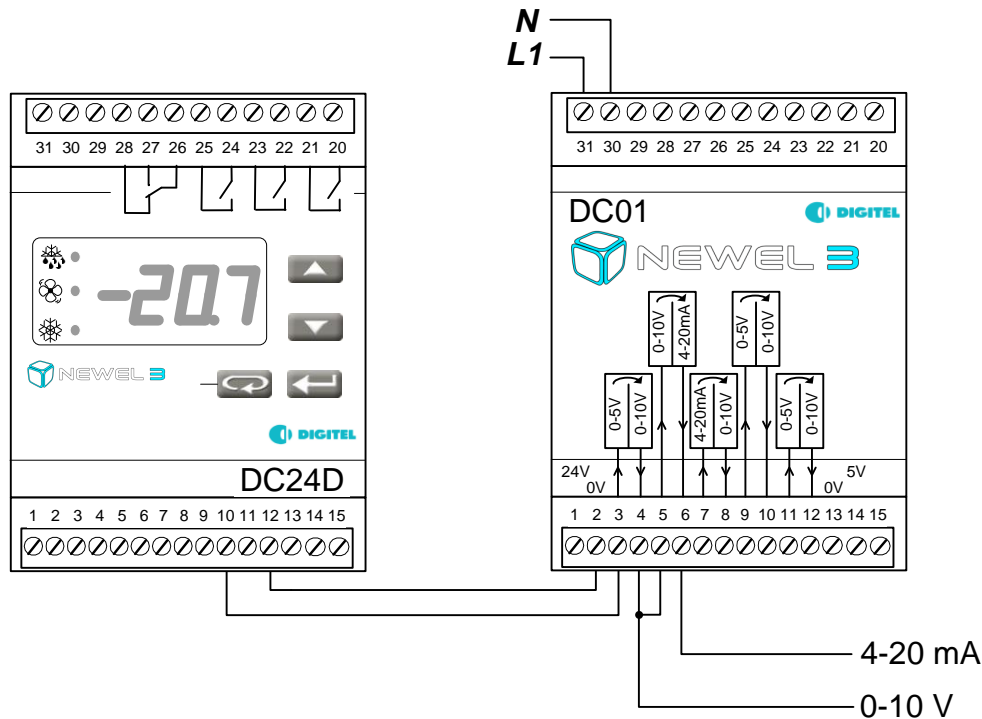

Figure 9.6.1

<b>[b2]</b>	Analogue output – Humidity corresponding to 0% (Analogue output menu)
<b>[b3]</b>	Analogue output – Humidity corresponding to 100% (Analogue output menu)
<b>[E1]</b>	Lower alarm limit (Security menu)
<b>[E2]</b>	Upper alarm limit (Security menu)
<b>[o4]</b>	Function of contact C1 (Settings menu)
<b>[o6]</b>	Function of contact C2 (Settings menu)
<b>[U1]</b>	Setpoint (Regulation menu)
<b>[U5]</b>	Setpoint offset (Regulation menu)
<b>[U6]</b>	Start of setpoint offset (Regulation menu)
<b>[U7]</b>	End of setpoint offset (Regulation menu)

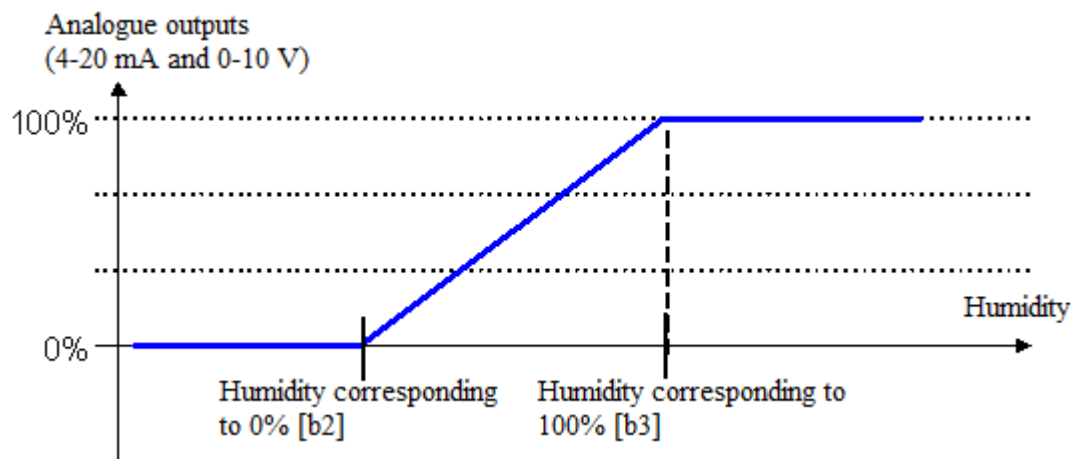

Figure 9.6.2

## 9.7. C1, C2 CONTACTS

The functions of contacts C1 and C2 will be determined by parameters **[o4]** and **[o6]**. These may function as alarm contacts, shutdown contacts or setpoint offset contacts.

---

**[o4]** Function of contact C1 (Settings menu)

**[o6]** Function of contact C2 (Settings menu)

## 9.8. PARAMETERS

### Basic configuration

Sym.	Lvl.	Function	comments	Default value	Value applied
PAS	0	Password		0	
r1	3	Mode of operation <i>0 = cooling unit 1 = Management of compressors 2 = Universal regulation 3 = Monitoring 4 = Management of evaporators 2, 3, etc.</i>		2	
AD	3	Module's address <i>Don't change it when the module is connected to a DI58/DC58 central unit</i>			

### Parameters

	Sym.	Lvl.	Function	comments	Default value	Value applied
	PAS	0	Password		0	
Regulation	U1	2	Setpoint (%)		70	
	U2	2	Delta for dehumidification limit (%)		2	
	U3	2	Neutral zone (%)		2	
	U4	2	Delta for humidification (%)		2	
	U5	2	Setpoint offset (%)		0	
	U6	2	Start of setpoint offset (HH.M)		0	
	U7	2	End of setpoint offset (HH.M)		0	
Analogue output	b1	2	Function of analogue output <i>0 = proportional to the measured humidity</i>		0	
	b2	2	Analogue output – humidity corresponding to 0% (%)		50	
	b3	2	Analogue output – humidity corresponding to 100% (%)		80	
Safety	E1	2	Lower alarm limit (%)		55	
	E2	2	Upper alarm limit (%)		80	
	E3	2	Alarm delay (min)		30	
Settings	o0	2	Sensor type 0 = 4-20mA 1 = 0-10V		0	
	o1	2	Range of measurement of hygrometry sensor – Lower limit (%)		0	
	o2	2	Range of measurement of hygrometry sensor – Upper limit (%)		100	
	o3	2	Correction of sensor (%)		0	
	o4	2	Function of contact C1 <i>0 = alarm upon closure 3 = display 1 = alarm upon opening 4 = setpoint offset upon contact closure 2 = shutdown</i>		0	
			Alarm delay (min)	o4 = 0 ou 1	30	
	o6	2	Function of contact C2 <i>0 = alarme à la fermeture 3 = visualisation 1 = alarme à l'ouverture 4 = décalage de la consigne à la fermeture du contact 2 = arrêt</i>		0	
			Alarm delay (min)	o6 = 0 ou 1	30	
	o8	2	Level 1 password (user)		0	
	o9	2	Level 2 password (operating engineer)		0	
o10	2	Level 3 password (installer)		0		

Alarms	A1C	2	Code of most recent alarm
	A1d	2	Day of most recent alarm
	A1b	2	Month of most recent alarm
	A1H	2	Hour of most recent alarm
	A1M	2	Minute of most recent alarm
	A2C	2	Code for last alarm but one
	A2d	2	Day of last alarm but one
	A2b	2	Month of last alarm but one
	A2H	2	Hour of last alarm but one
	A2M	2	Minute of last alarm but one
	A...C		etc., up to 5 alarms

## Codes des alarmes

Alarms	<i>Codes des alarmes</i>	
	1	Measured variable too low
	2	Measured variable too high
	3	Hygrometry sensor not connected
	4	Hygrometry sensor short-circuited
	13	Alarm contact C1
14	Alarm contact C2	