

# TRANSCRITICAL CO<sub>2</sub>

The gradual reduction in the use of fluorinated gases has led to the use of more environmentally friendly refrigerants. With its high heat transfer efficiency, CO<sub>2</sub> has quietly emerged as the natural refrigerant of the future. High-efficiency technological developments, such as ejectors and parallel compressors, have given a new perspective to CO<sub>2</sub> refrigeration in both cold and warm climates.

## A full range of control products for CO<sub>2</sub> refrigeration

Since 2014, Digitel has provided a comprehensive portfolio of control and monitoring tools specifically designed to manage transcritical CO<sub>2</sub> installations.

Our CO<sub>2</sub> control solutions follow the same philosophy that we have been applying since 1989 to the design of all our products: to develop state-of-the-art products that simplify the life of the users. This is even more true for CO<sub>2</sub> installations, which are becoming more and more complex as technologies evolve rapidly. The graphical interface offered by our Teleswin remote management software is very user-friendly and facilitates the understanding and maintenance of these installations.

## Unique solutions for more economical operation

Digitel has developed tools to increase the efficiency of transcritical CO<sub>2</sub> installations, such as heat recovery management and optimization of HP and gas cooler setpoints. Digitel's control solutions for the latest efficiency-enhancing technologies, such as parallel compressors and liquid and gas ejectors, have been optimized in partnership with refrigeration engineers on real installations, giving them unique performance.

In addition, the deployment of Digitel's new AI Energy tool provides monitoring of the energy consumption of cooling units. Overconsumption above a certain threshold is reported to the user and allows rapid action to be taken on the energy consumption of the installation.

For large installations, such as supermarkets or hypermarkets with many cooling units, the economic impact is significant.



# TRANSCRITICAL CO<sub>2</sub> BOOSTER

## 1 Transcritical CO<sub>2</sub> controllers

With Digital controllers, the management of a transcritical CO<sub>2</sub> installation is handled with only two DC24TR controllers, which take over the control of the gascooler, the high and medium pressure, and the interface with the heat recovery system.

MP and HP management  
Gascooler management



## 2 Compressors controllers

The Digital DC24D controller is capable of controlling up to three compressors. For larger installations, multiple satellites can be chained together with the help of the local bus.

Medium temperature compressor  
Low temperature compressor

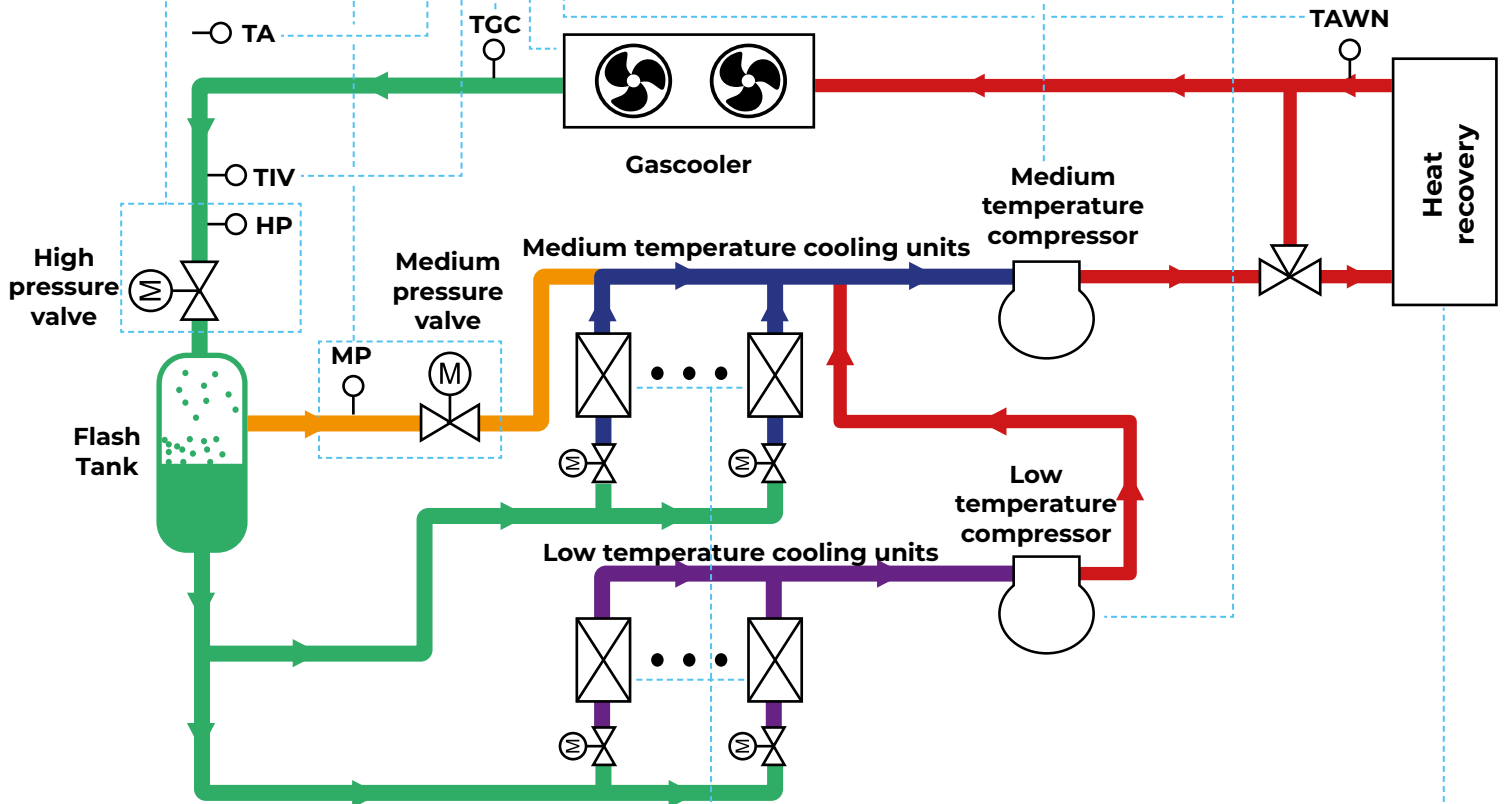

## 7 Furnitures and cold rooms controllers

Digital provides the tools to manage positive and negative cooling units. Five temperature sensors and one pressure sensor can be connected to a controller. Several defrost modes, including an intelligent defrost optimization mode, are available. Electronic pulse or progressive expansion valves (stepper motors) can be managed.

DIN rail controller



Flush-mounted controller



## 6 Heat recovery controllers

Refrigeration systems, specifically those using CO<sub>2</sub> as a refrigerant fluid, generate large amounts of heat.

In order to reduce operating costs, this energy can be used to heat domestic water or to heat offices or sales areas. The heat recovery is managed by two Digital DC24TR controllers.



# PARALLEL COMPRESSORS AND EJECTORS

## 3 Compressors monitoring

DC25 compressors monitoring units can be added for more detailed monitoring of the compressors.



DC25

## 4 CO<sub>2</sub> concentration monitoring

Digitel offers a simple solution for measuring and monitoring CO<sub>2</sub> concentration, as the CO<sub>2</sub> sensors can be directly connected to the DC24D/DE controllers that run the cooling stations or compressor plants. Thanks to this integrated solution, there are no additional modules or cables and the installation costs are reduced. Alarm panels and an audible alarm can be controlled by the module.

## 5 Monitoring software

The installation is supervised and managed remotely by the Teleswin remote management software.

CO<sub>2</sub> concentrations and alarms can be read remotely with the supervision software.

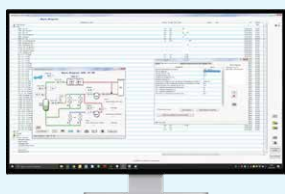

TELESWIN

## 1 Ejectors controllers

Liquid ejector controller



DC24TRE

Gas ejector controller 1 to 4



DC24TRE

The liquid ejector is very useful to maximize the utilization potential of the evaporators. Thanks to the aspiration bottle and the liquid ejector, the superheat can be lowered to 0 K without having to worry about liquid return to the compressors. The liquid ejector is controlled by a Digitel DC24TRE controller.

The gas ejector reduces gas compression by diverting part of the low pressure CO<sub>2</sub> to the high pressure CO<sub>2</sub> after the gascooler.

A Digitel DC24TRE controller controls up to 4 ejector electrovalves. For larger ejectors, a second controller can be added.

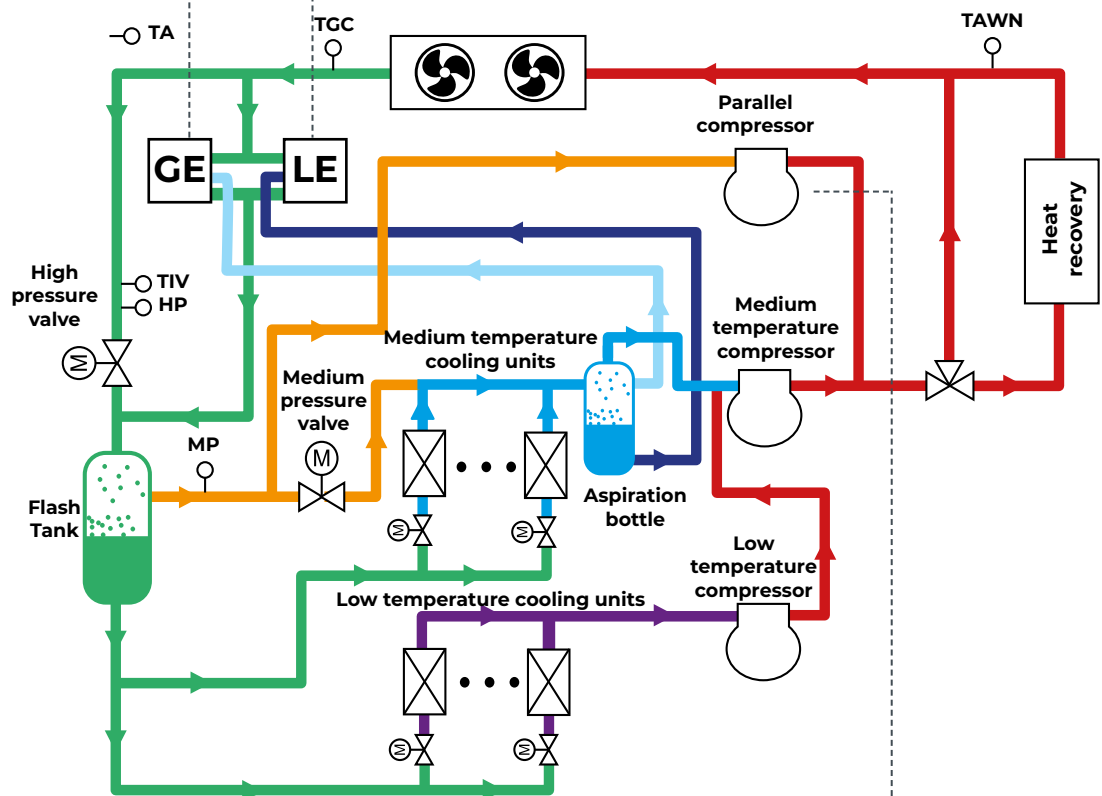

## 2 Parallel compressors controllers

The purpose of the parallel compressors is to recompress the gas in the flash tank to reduce the opening of the medium pressure valve. The parallel compressors reduce the load on the medium temperature cooling unit and thus reduce the energy consumption.

The parallel compressors are controlled by a Digitel DC24D controller, which can control up to three compressors.

Parallel compressor



DC24D

# PRODUCT GRID FOR TRANSCRITICAL CO<sub>2</sub> REGULATION

	Transcritical CO <sub>2</sub> booster	Liquid ejectors with booster	Booster with liquid and gas ejectors and parallel compressors
Software monitoring	DC58-1, -2 ou -3 (according to the size of the installation) + Teleswin		
Compressors controller	Medium temperature compressor: 1x DC24D (up to 3 compressors) Low temperature compressor: 1x DC24D (up to 3 compressors)		
HP, MP and gascooler controller	2x DC24TR + 1x DC01		
Ejectors controller	Liquid ejector: 1x DC24TRE Gas ejector: 1x DC24TRE (up to 4 valves)		
Parallel compressors controller	1x DC24D (up to 3 compressors)		

## + IN OPTION:

Compressors monitoring	Medium temperature compressor: 1x DC25 (up to 3 compressors) Low temperature compressor: 1x DC25 (up to 3 compressors)		
Heat recovery controller	2x DC24TR + 1x DC01		
CO <sub>2</sub> concentration monitoring	DC-CO <sub>2</sub> or DC-CO <sub>2</sub> L		
Desuperheater or subcooler controller	DC24D or DC24DE		



## About us

Digitel provides high-end control solutions, monitoring and remote management solutions for installations requiring a high degree of performance: refrigeration, heat recovery, controlled atmosphere chamber, growth chamber or even special installations.

[www.digitel.swiss](http://www.digitel.swiss)

## Distribution



## Headquarter

Digitel SA  
Route de Montheron 12  
1053 Cugy, Suisse

T: +41 21 731 07 60  
E : [info@digitel.swiss](mailto:info@digitel.swiss)