

Compressor safety chain monitoring module

DIN rail housing, display, 230 VAC power supply.

The DC25 module allows a more detailed monitoring of the compressors with 5 digital 230 VAC inputs per compressor, up to three compressors.

The first three inputs allow the following monitoring

- Compressor safety,
- Oil pressure switch,
- HP pressure switches.

Their status is indicated on the controller display. The functions of the next two inputs can be configured in the parameters (e.g. alarm triggering, compressor shutdown, etc.).

Remote management with the Teleswin software indicates which part of the safety chain is interrupted and allows an initial diagnosis to be made remotely.

The module is mounted on DIN rails.



APPLICATIONS

Management of compressors	yes
---------------------------	-----

DIMENSIONS

Module

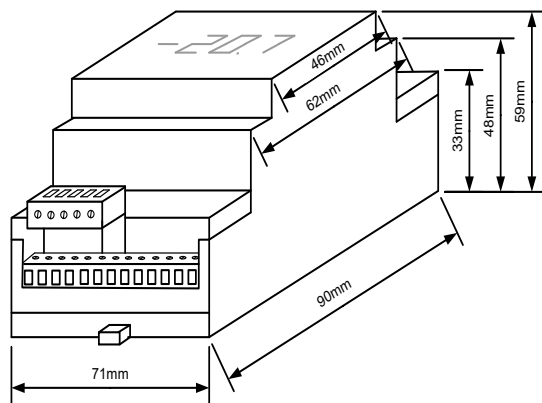

Cut-out for display

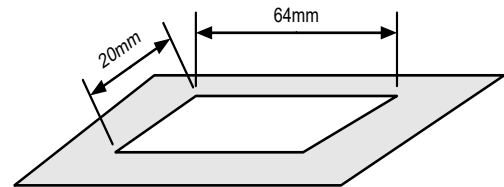

FEATURES

Inputs	3x5 inputs 230 VAC (5 inputs per compressor)
White display	yes
Power supply	230 VAC
Remote monitoring bus interface	no
Clock	no
Electronic expansion valve	no
Local bus for extensions	yes

TECHNICAL DATA

Power supply	
Supply voltage	110-250 VAC, 50-60 Hz
Maximum input power	4 W
Protection rating	1
Contamination rating	2
Overvoltage category	II
Operating conditions	
Temperature	0-40° C
Humidity	0-80% (without condensation)

ASSEMBLY DIAGRAMS

DC25 controller display

In normal operation, the DC25 display shows the status of the securities. A flashing segment indicates that the corresponding security contact is off.

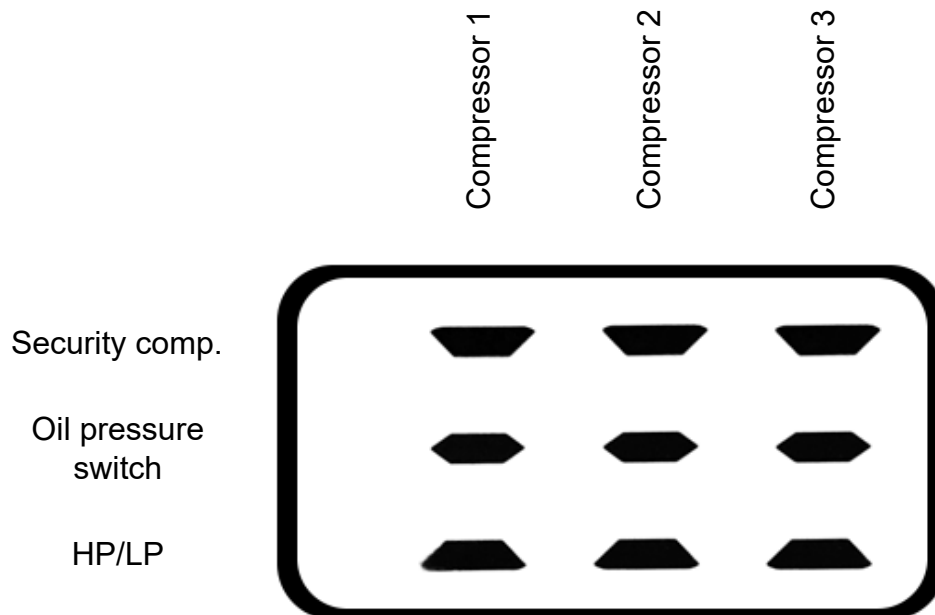

Compressors Security

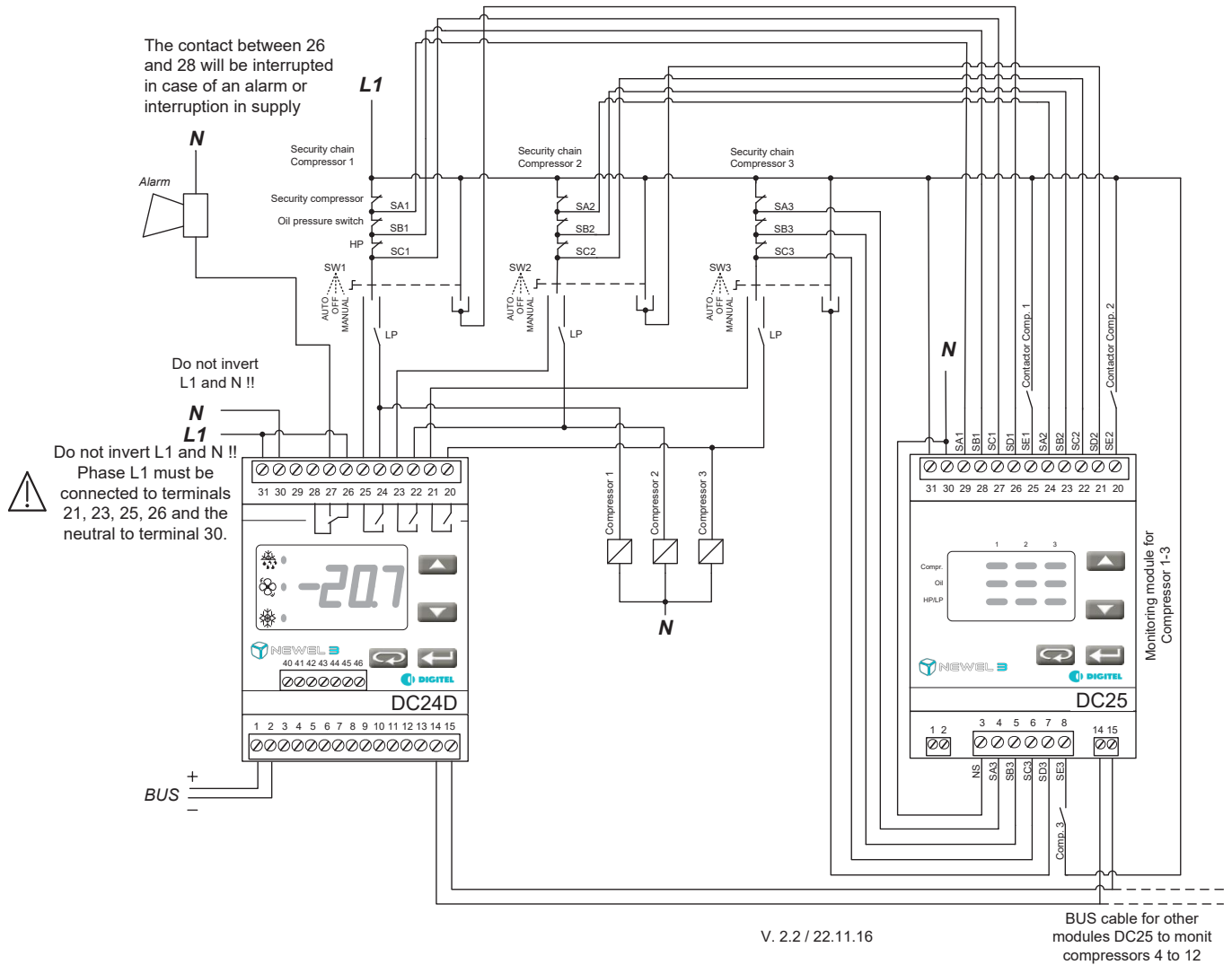

About us

Digitel provides high-end control, monitoring and remote management solutions for installations requiring a high degree of performance: refrigeration, heat recovery, controlled atmosphere chamber, growth chamber or special and customized installations.

Digitel SA
Route de Montheron 12
1053 Cugy, Suisse

T: +41 21 731 07 60
E : info@digitel.swiss

www.digitel.swiss