



NEWEL 3



USER MANUAL

DC24 – MANAGEMENT OF COOLING UNITS

Digitel reserves the right to modify the technical characteristics described without prior notice.

Non-contractual document

Digitel SA

All rights reserved

3. MANAGEMENT OF COOLING UNITS

3.1. INTRODUCTION

It is assumed that the reader of this document will previously have read the chapter 1 [Introduction to NEWEL3](#) The latter describes all the basic concepts which are essential to an understanding of the present document, and of the concept of the NEWEL3 product range in general.

This manual describes the operation of slave units for the **regulation of cooling units**. In this case, the parameter **[r1]** in the basic configuration will be programmed to 0.

3.2. CONNECTION

Connections will be completed in accordance with the circuit diagrams shown in [Figure 3.2.1 DC24D](#) and [Figure 3.2.2 DC24E](#).

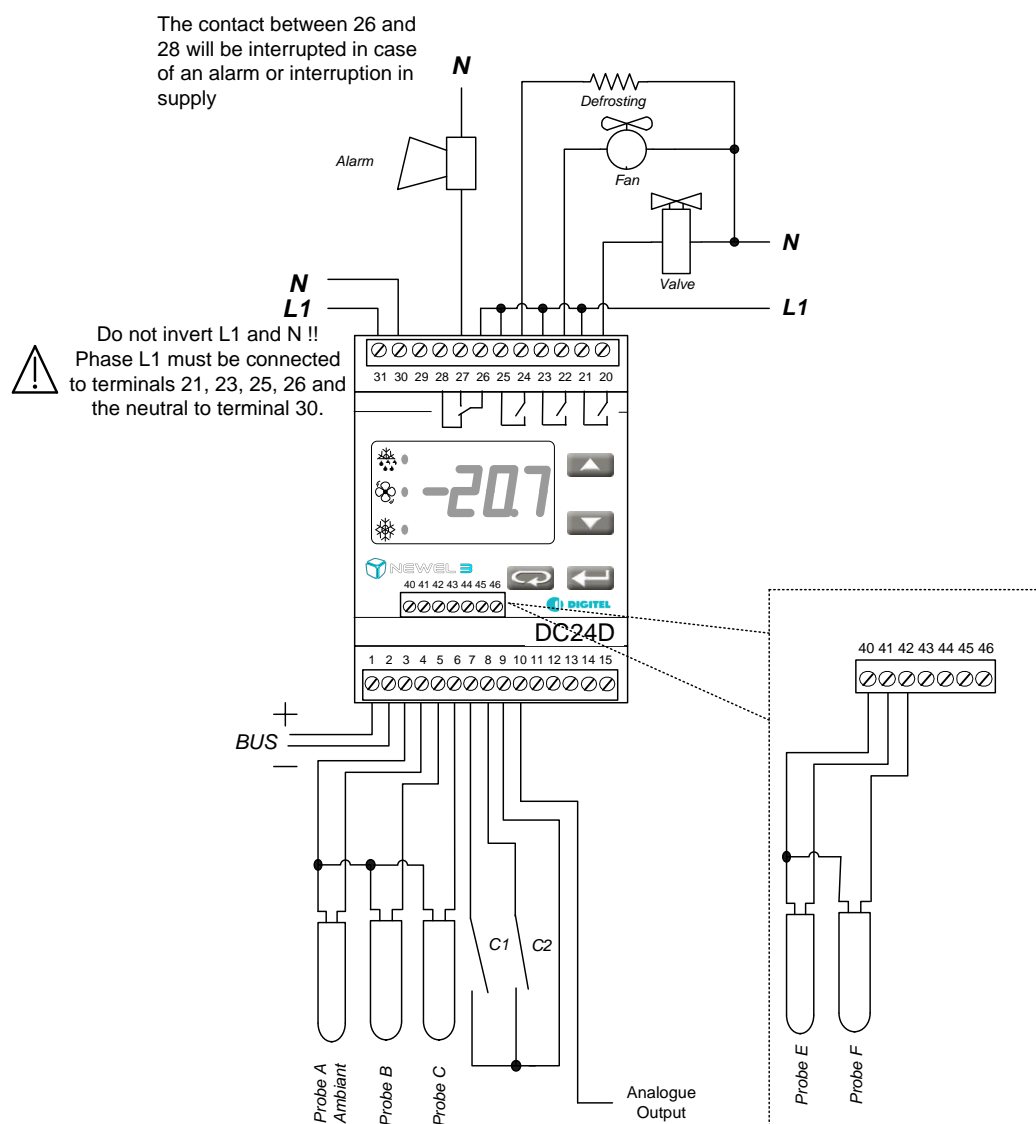

v1.1 / 15.11.2016

Figure 3.2.1 DC24D

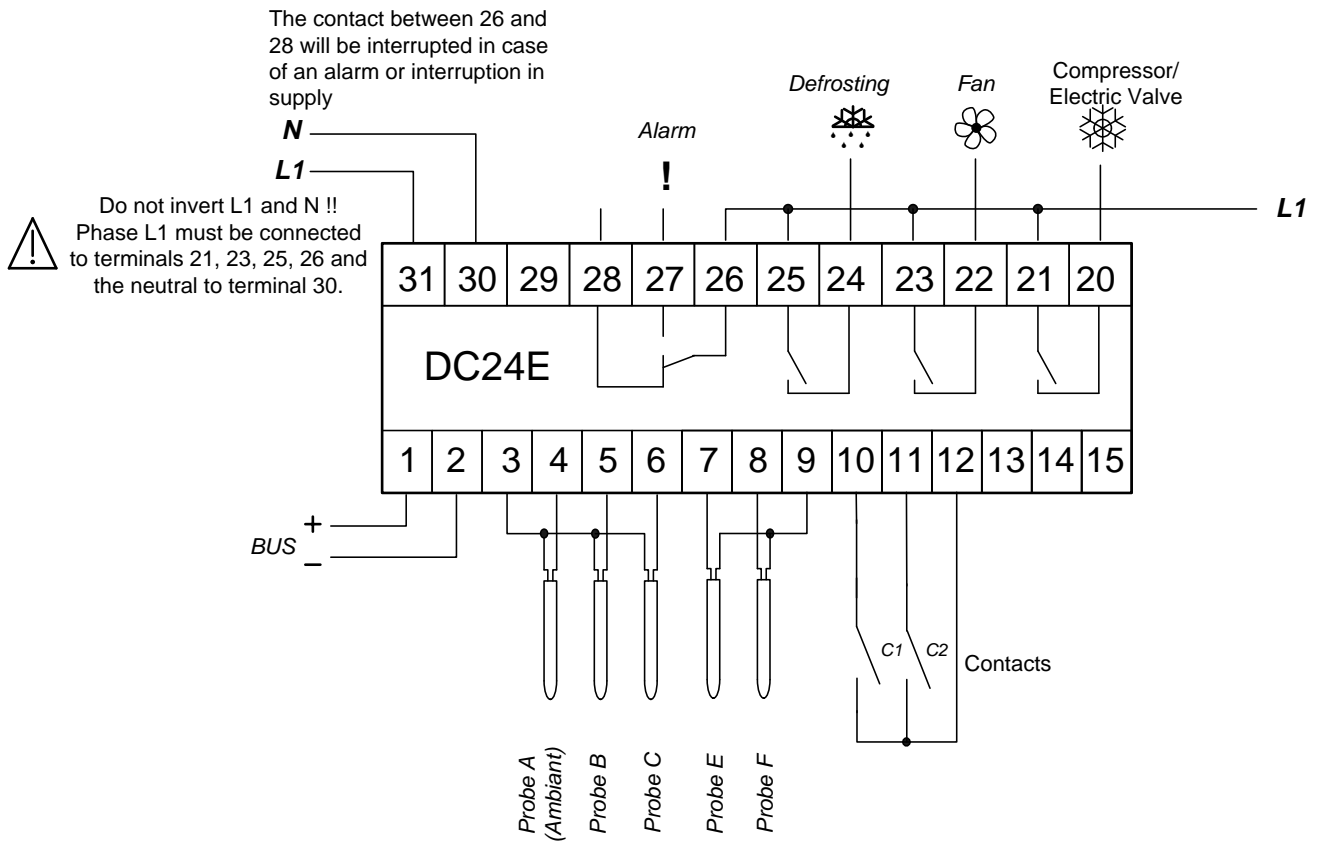

Figure 3.2.2 DC24E

Five temperature probes, designated A, B, C, E and F, may be connected to a satellite unit. The first of these will assume the role of an ambient probe. This probe is used for the regulation of temperature between the values **[t1]** and **[t1] + [t2]**.

The setpoint is programmable within a range of **[t3]** - **[t4]**.

The high and low ambient temperature alarm thresholds are adjustable in parameters **[t5]** and **[t6]**, while the delay is programmable in **[t7]**. Probe B, installed in the evaporator, controls the end of defrosting and delivers the command function for the fan. In positive temperature cooling units, with no electrical defrosting, this probe is not mandatory. The parameter **[d1]** will define whether the probe B is present or not. Probe C is also optional. This probe may be used for the measurement of the core temperature of products, or for the execution of a two-probe regulation function (see Chapter 3.3 Regulation with 2 probes). Alarm limits and the alarm delay will also be programmable for probes B and C in the corresponding menus.

[d1]	Is probe B present (Defrosting menu)
[t1]	Setpoint (T. ambient menu)
[t2]	Delta (T. ambient menu)
[t3]	Lower setting limit for setpoint (T. ambient menu)
[t4]	Upper setting limit for setpoint (T. ambient menu)
[t5]	Lower alarm limit (T. ambient menu)
[t6]	Upper alarm limit (T. ambient menu)
[t7]	Alarm delay (T. ambient menu)

The probe E can be used for measuring the overheat in case of a electronic expansion valve. With the thermostatic expansion valve it can supervise a temperature point. Its alarm limits and its delays can be set in the parameters **[E2]**, **[E3]** and **[E4]**.

The probe F is optional and can be used as supervising a supplementary temperature point. Its alarm limits and its delays can be set in the parameters **[E6]**, **[E7]** and **[E8]**.

The modules hardware is optimised for the measuring of PT1000 temperature probes. Other probe types are also compatible (See chapitre [1.10](#))

It is possible to define a minimum on-time and a minimum shutdown time for the compressor/valve using the parameters **[t11]** and **[t12]**.

The functions of contacts C1 and C2 are determined by parameters **[F1]** and **[F4]**. These may function as alarm contacts (with delays programmed by parameters **[F2]** and **[F5]**), setpoint offset contacts or contacts for the complete shutdown of the unit. Contact C1 may also be parameterized as a door contact. In this case, it may interrupt the supply to the solenoid valve and the fan when the door opens. Upon the closure of the door, reclosing will be completed after the time interval programmed in parameter **[F3]**. An alarm will be actuated where the duration of the door opening exceeds the time programmed in parameter **[F2]**. The fan and the solenoid valve will also restart after this time interval, even if the door remains open.

Contact C2 may be used for the management of defrosting operations – see [3.4.7 Defrosting pulse \(contact C2 function=defrosting pulse \[F4=5\]\)](#): and [3.5 Management of multi-evaporator unit](#).

3.3. REGULATION WITH 2 PROBES

The temperature may be regulated using 2 probes. Using the measurements from probe A and probe C, the module will calculate an estimated product temperature using the following formula:

$$t_{Virtual} = \frac{probeA \cdot (100 - C5)}{100} + \frac{probeC \cdot C5}{100}$$

This virtual temperature is used as a regulated value. The parameter **[C5]** indicates the significance of probe C in relation to probe A (in percentage terms) in the estimation of the virtual temperature. Where probe C is absent (**[C1]** = 0) or the parameter **[C5]** = 0, only probe A will be used for regulation.

When parameter **[E9]** is on 1, the probe F will be replaced by the virtual probe. The display and the alarm management of the probe F will refer to the virtual probe and not the physical probe. In this case, the input of the probe F is disabled.

[C1]	Probe C is present (Probe C menu)
[C5]	Significance of probe C in the estimation of virtual temperature (Probe C menu)
[F1]	Operation of contact C1 (Setting menu)
[F2]	Alarm delay for contact C1 (Setting menu)
[F3]	Time delay for valve and fan after door closure (Setting menu)
[F4]	Operation of contact C2 (Setting menu)
[F5]	Alarm delay for contact C2 (Setting menu)
[t11]	Minimum operating time (T. ambient menu)
[t12]	Minimum resting time (T. ambient menu)
[E2]	Lower alarm limit probe E (°C)
[E3]	Upper alarm limit probe E (°C)
[E4]	Alarm delay probe E (min)
[E6]	Lower alarm limit probe F (°C)
[E7]	Upper alarm limit probe F (°C)
[E8]	Alarm delay probe F (min)
[E9]	Probe F is a 0 = real, 1 = virtual probe

3.4. DEFROSTING

Various types of defrosting will be programmable using [d2]:

3.4.1. ELECTRICAL DEFROSTING ([D2=0])

In this case, defrosting operations will commence at the times programmed in parameters [d8 – d13] and will end when the defrosting temperature achieves the maximum limit [d5] or when the maximum duration programmed in parameter [d6] has been exceeded. Time intervals should be programmed with a maximum duration of sufficient length to ensure that, in all cases, the end of defrosting will be controlled by the evaporator probe. The interruption of defrosting by the overrun of a programmed time interval should only occur in case of a fault on a probe or the failure of the heating system; an alarm will be triggered as a result. During defrosting, the valve will be closed. The valve will open when the evaporator achieves the end of defrosting temperature [d5] and the valve delay time after defrosting (run-off) has elapsed (parameter [d3]). The parameter [d7] will allow the elimination of certain defrosting operations which will not be essential during periods of low demand for refrigeration. The satellite unit will compute the total valve opening time since the last defrosting operation in the parameter "Duration of valve opening since last defrosting" in the Info (TelesWin) menu. Before each defrosting operation, this time will be compared with the value entered for parameter [d7]. If this value is lower (indicating that the demand for refrigeration since the last defrosting operation has been low), the defrosting operation to be executed will be ignored. By programming a zero value for this parameter, this criterion will be rendered inoperative.

If the value is negative, the module will start a defrosting if the electrovalve has been open, since the last defrosting, longer than the absolute value (hours) of the programmed value of this parameter. For example, if the parameter is set at -4, a defrosting will be launched if the electrovalve has been open for 4 hours since the last defrosting. In this case, the defrosting times, set in the parameters [d8 to d13], are ignored.

3.4.2. AIR DEFROSTING WITH FAN ([D2=1]):

In cold stores with positive temperatures, the use of heating for the completion of defrosting operations may be superfluous. In this case, the valve will be closed during defrosting, while the fan will remain connected to supply. This type of defrosting will not require an evaporator probe.

3.4.3. AIR DEFROSTING WITHOUT FAN ([D2=2]):

Operates in the same way as the defrosting operation described above, but with the fan disconnected from supply.

3.4.4. ECONOMY DEFROSTING ([D2=3]):

In this case, fan-assisted air defrosting will be completed during the time programmed in parameter [d6]. If, once this time has elapsed, the evaporator temperature is lower than parameter [d5], electrical defrosting will be initiated. If this is not the case, the heating system will not start up. An evaporator probe will be required for this purpose.

3.4.5. DEFROSTING WITH CLOCK FUNCTION ([D2=4]):

Where this parameter is programmed accordingly, defrosting will proceed as per electrical defrosting, but no alarm will be triggered where the maximum defrosting time is exceeded. The defrosting probe will not be mandatory.

[d2]	Type of defrosting (<i>Defrosting menu</i>)
[d2]	Type of defrosting (<i>Defrosting menu</i>)
[d3]	Valve delay time after defrosting (<i>Defrosting menu</i>)
[d5]	End of defrosting temperature (<i>Defrosting menu</i>)
[d6]	Maximum duration of defrosting (<i>Defrosting menu</i>)
[d7]	Defrosting cancelled if valve opening time is less than (<i>Defrosting menu</i>)
[d8]	Start of defrosting n° 1 (<i>Defrosting menu</i>)
[d13]	Start of defrosting n° 6 (<i>Defrosting menu</i>)

3.4.6. HEATING AND CLIMATISATION COMMAND. ([D2=5]):

In this case, the defrosting relay will be used to regulate the heating system, and will be controlled by the ambient probe.

The operation of the refrigeration system is similar to that described above. In the case of heating, where the temperature measured by the ambient probe falls below $[t1] - [d4] - [d5]$, the heating contact will close, and where the ambient temperature rises above $[t1] - [d4]$, the contact will open and heating will be interrupted.

This operation is represented graphically in the diagram below:

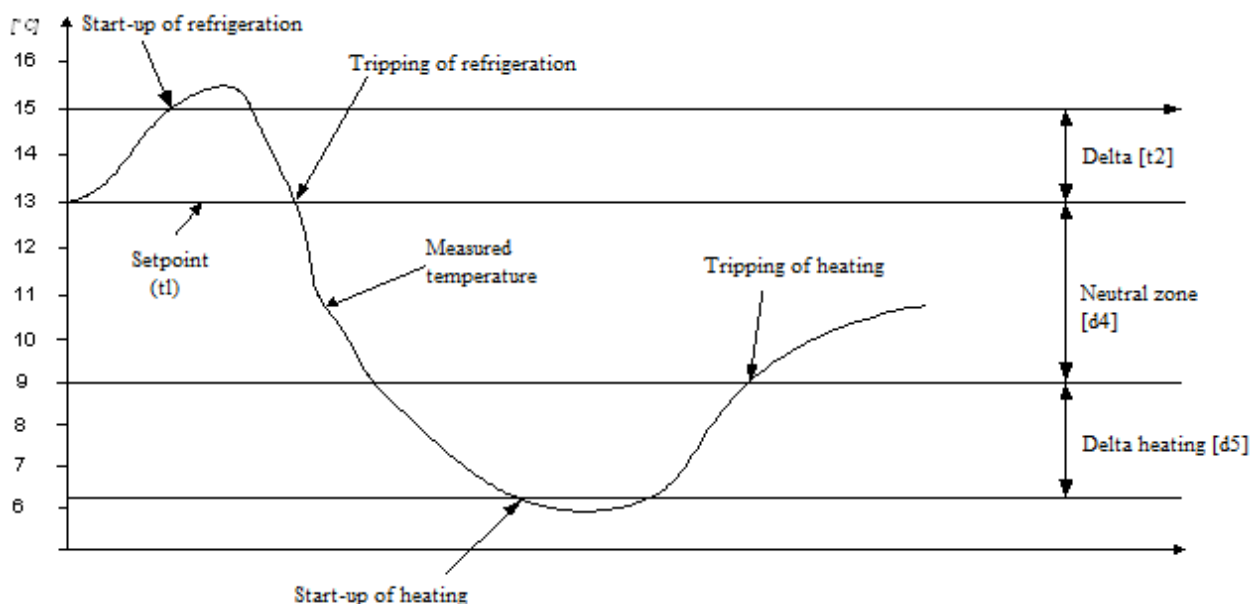

Figure 3.4.1

3.4.7. DEFROSTING PULSE (CONTACT C2 FUNCTION=DEFROSTING PULSE [F4=5]):

In this case, defrosting will be initiated when the contact C2 closes for over 2 seconds, provided that there is no defrosting operation already in progress. Defrosting will terminate when the end of defrosting temperature is achieved or the maximum defrosting time has elapsed, regardless of the status of contact C2.

Some "temperature to high" alarms will be inhibited during the defrostings and their delay will be reset once the defrosting is ended. This concerns the alarm of probe A, the alarm of probe C if it is used for the calculation of the virtual temperature and the alarm of probe F if parameter **[E9]** is set at 1.

[d2]	Type of defrosting (Defrosting menu)
[d4]	Neutral zone for heating/refrigeration (T. ambient menu)
[d5]	Delta heating (T. ambient menu)
[F4]	Function of contact C2 (Setting menu)
[t1]	Setpoint (T. ambient menu)
[E9]	Probe F is a 0 = real, 1 = virtual probe

3.5. MANAGEMENT OF MULTI-EVAPORATOR UNIT

Where installations are equipped with a number of evaporators with electrical defrosting, two options are possible:

1. Each evaporator is controlled by a separate solenoid valve. Defrosting operations on all evaporators may proceed simultaneously or separately.
2. All evaporators are supplied by the same solenoid valve, and will defrost at the same time.

In the first case, each evaporator will be considered as an independent cooling unit, and will be managed by a separate satellite unit. Connections will be completed in accordance with [Figure 3.2.1 DC24D](#), [Figure 3.2.2 DC24E](#)

In the second case, connections will be completed in accordance with [Figure 3.5.1](#), [Figure 3.5.2](#)

The 2 satellite units will be programmed as follows:

Master (management of first evaporator, valve and fan):

- **operating mode:** “cooling unit” **[r1=0]**
- “electrical” **defrosting** **[d2=0]**
- **defrosting times, maximum duration, end of defrosting temperature**, etc.
- **operation of contact C2** “monitoring of defrosting on additional evaporators” **[F4=6]**

Slave(s) (management of subsequent evaporators):

- **operating mode:** “management of evaporators 2 – 4” **[r1=4]**
- **maximum duration, end of defrosting temperature** in the *Defrosting* menu will be programmed as per the main unit.

Each evaporator will be provided with a defrosting output and a separate end of defrosting probe. The defrosting of the first evaporator will simultaneously initiate the defrosting of the other evaporators by the generation of a defrosting “pulse” on the C2 input of the slave satellite unit. Defrosting operations will be interrupted separately on each evaporator, upon the achievement of the value programmed in parameter **[d5]**. The solenoid valve will open after the time delay programmed in parameter **[d3]**. This time delay will commence upon the completion of defrosting operations on all the evaporators (input C2 on the master satellite unit will open).

Each probe is provided with a temperature alarm function.

[d2]	Type of defrosting (Defrosting menu)
[d3]	Valve delay after defrosting (T. ambient menu)
[d5]	End of defrosting temperature (T. ambient menu)
[F4]	Function of contact C2 (Setting menu)
[r1]	Operating mode (Basic configuration menu)

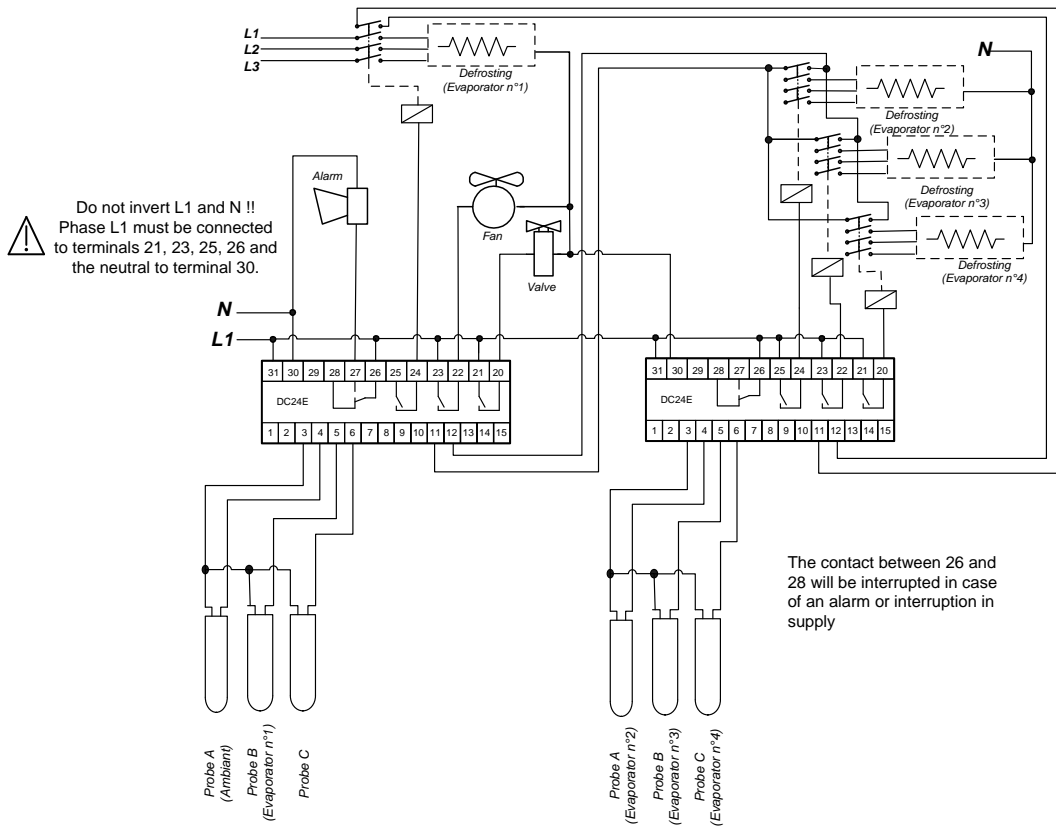

Figure 3.5.1

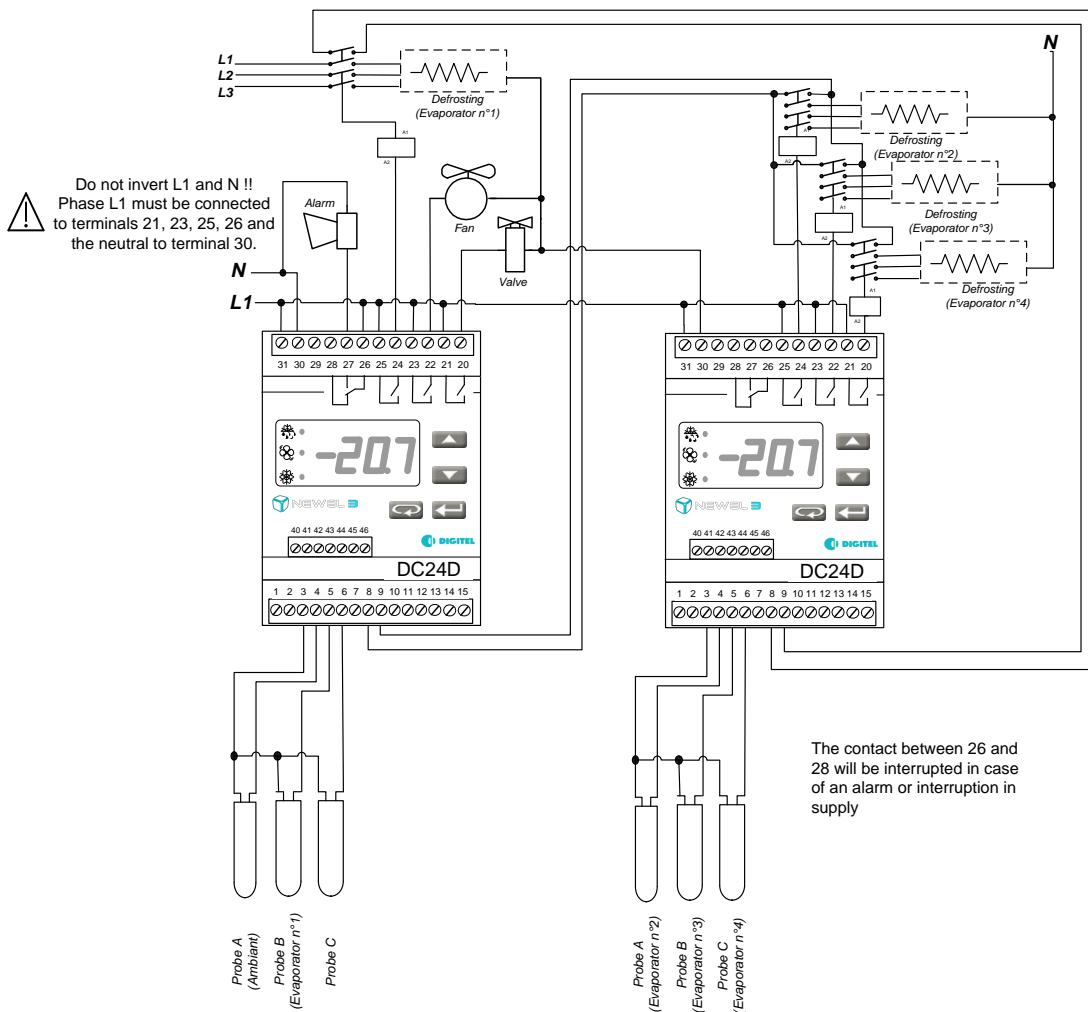

Figure 3.5.2

3.6. SPECIAL CONFIGURATIONS

In the standard applications, parameter **[F9]** is set to 0.

3.6.1. MANAGEMENT OF MULTIPLE STATION USING THE SAME MODULE

With parameter **[F9]** at 1, the alarm output controls defrosting of the second evaporator. The connections are made according to the diagram below:

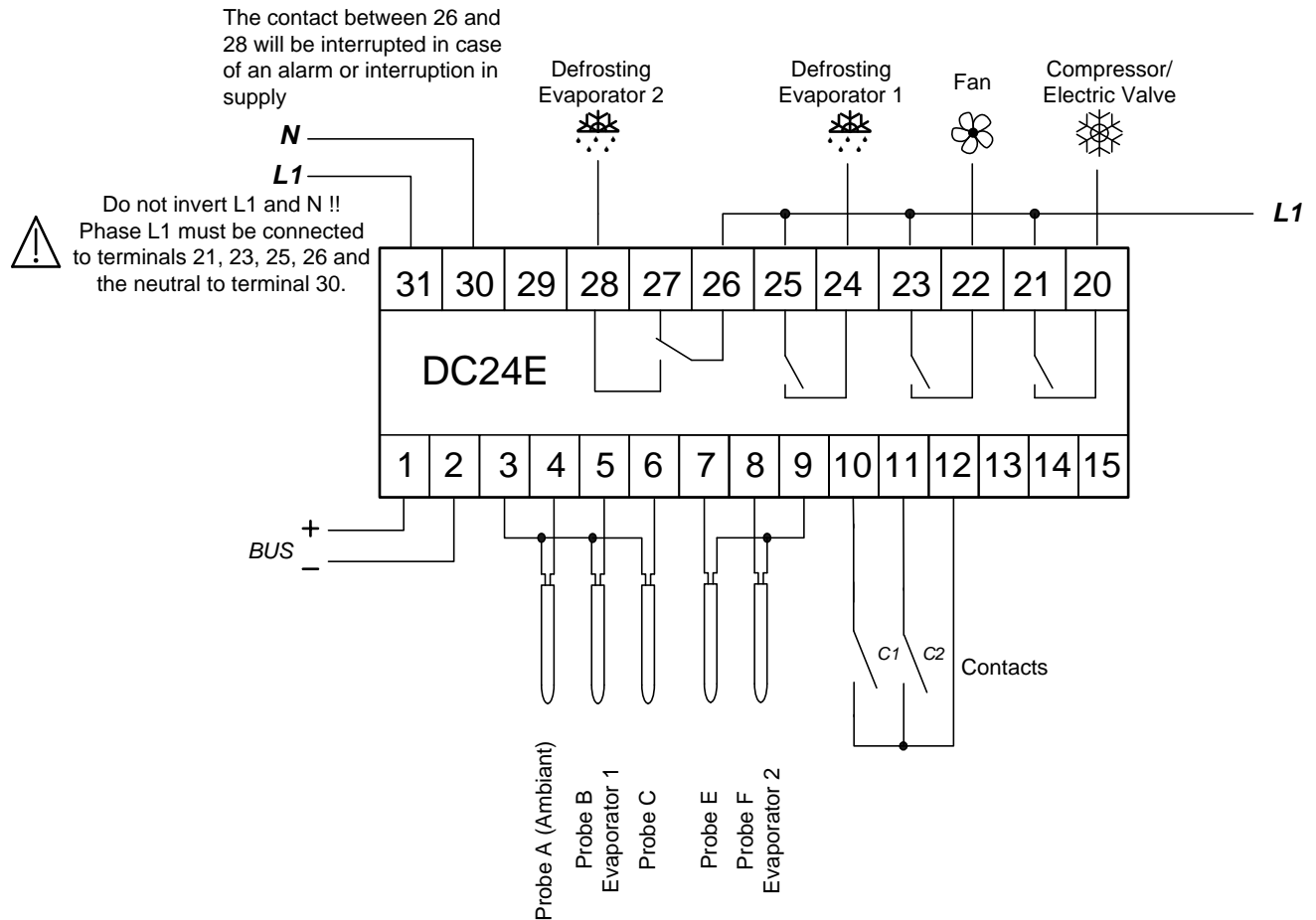

Figure 3.6.1

Defrosting of the two evaporators operate with the same parameters programmed in the "Defrost" menu. They engage at the same time, but their ends are controlled separately by probe B for evaporator no. 1 and probe F for evaporator no. 2. The cooling engages only after defrosting of both evaporators is completed and after a possible delay **[D3]**.

When parameter **[F9]** is at 2, the module controls three evaporators. In this mode, the fans are not controlled (they are in continuous operation). The connections are made according to the diagram below:

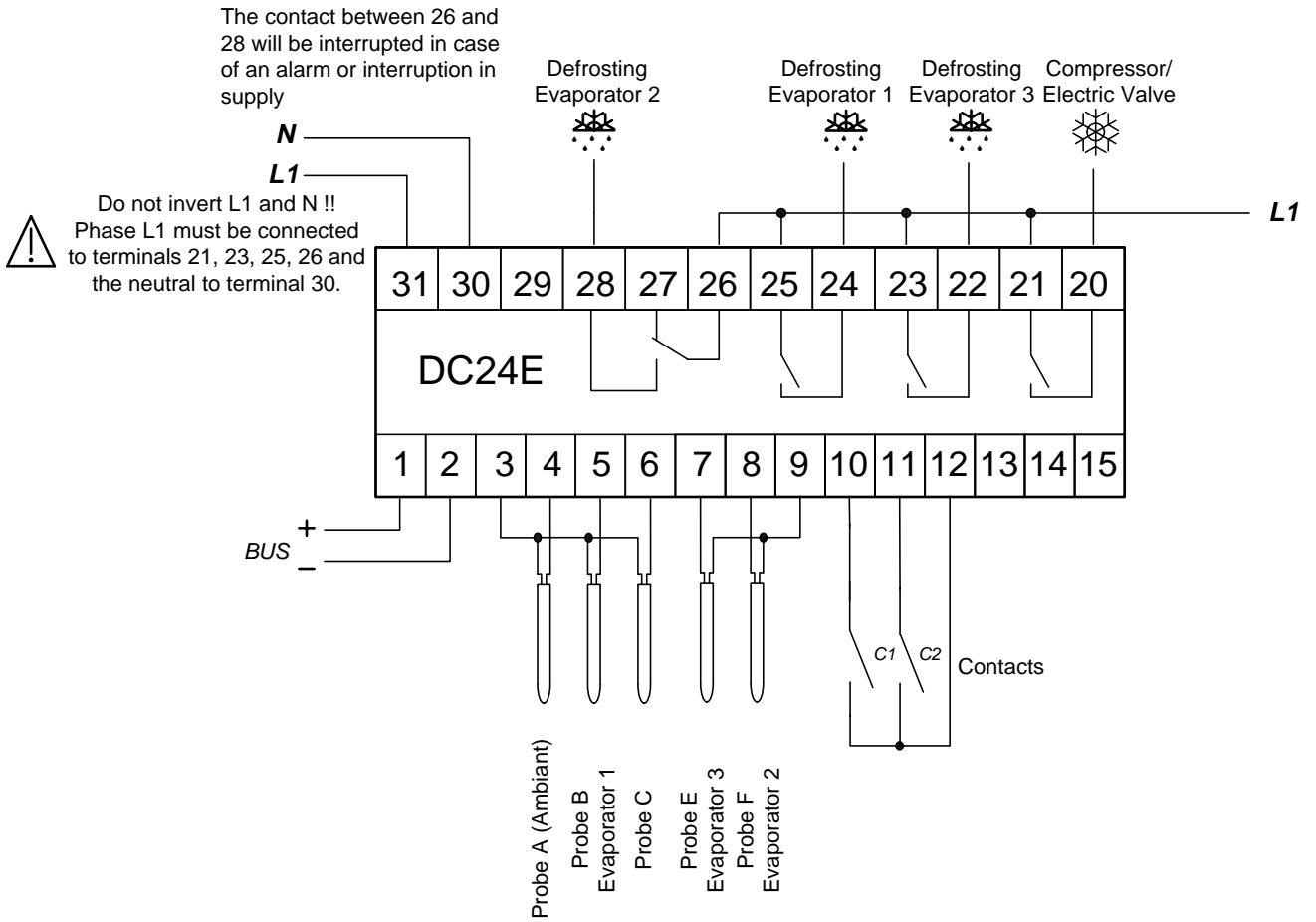

Figure 3.6.2

3.7. MANAGEMENT OF FAN

Fan operation (programmable with **[U1]**) can be set as follows:

- **[U1=0]** If the evaporator probe is present, the fan is switched off during and after defrosting until the temperature drops below parameter **[D4]**
- **[U1=0]** If the evaporator probe is absent, the fan is switched off during and after defrosting until the time programmed in parameter **[D4]**
- **[U1=1]** The fan is still running.
- **[U1=2]** The fan is controlled at the same time as the solenoid valve.
- **[U1=3]** The fan is controlled by the evaporator probe. It is switched on when the evaporator temperature falls below the value of parameter **[U2]** and it is triggered when the temperature exceeds value **[U3]**.

The fan and the valve are switched off when the door is opened and after closure until the time programmed in parameter **[F3]** has elapsed. This operation is cancelled when the parameter is 0.

3.8. ANALOGUE OUTPUT

This output is intended for the control of a DC01 module, which is provided with a 4-20 mA and 0-10 V output – see [Figure 3.8.1](#). This output is used for the regulation of the fan speed, the control of a three-way valve, electronic expansion valve, etc.

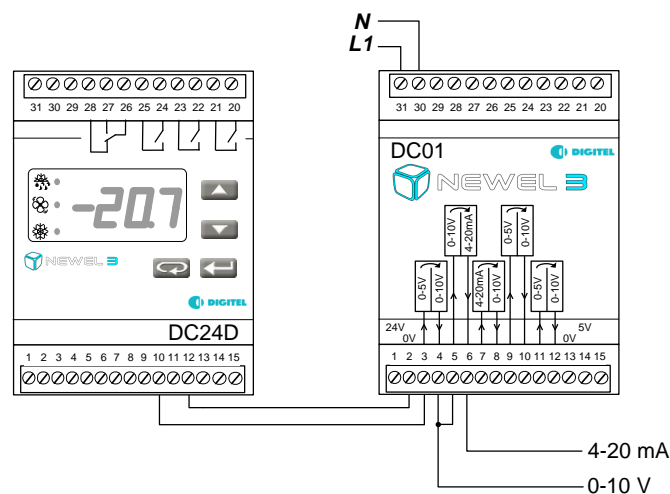

Figure 3.8.1

The function of this output is programmable in parameter **[b1]**, which may assume the following values:

- 0 – The output varies proportionally to the value of the temperature, between parameters **[b2]** and **[b3]**. Values for **[b2]** and **[b3]** are offset in parallel to the setpoint offsets.

[b1]	Operation of analogue output (Analogue Output menu)
[b2]	Analogue output – temperature corresponding to 0% (°C) (Analogue Output menu)
[b3]	Analogue output – temperature corresponding to 100% (°C) (Analogue Output menu)
[d4]	If Probe C is present: start-up temperature of fan after defrosting (Defrosting menu) If Probe C is absent: delay to fan start-up after defrosting (Defrosting menu)
[F3]	Delay to start-up of compressor/solenoid valve after door closure (Contact c1, c2 menu)
[U1]	Operation of fan (Fan menu)
[U2]	Start-up temperature of fan (°C) (Fan menu)
[U3]	Trip temperature of fan (°C) (Fan menu)

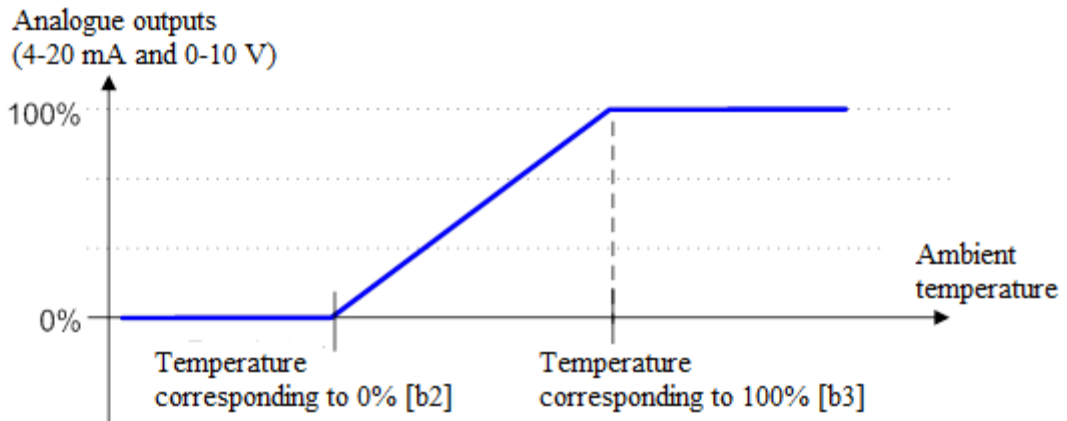

Figure 3.8.2

- 1 – PI type control. This type of control will permit, for example, the regulation of the rate of flow of the refrigerant(or heat conduction) fluid by means of a progressive valve, which is controlled by a 4-20 mA or 0-10 V input. Frequently used in large-scale fruit and vegetable stores, this form of control allows a high degree of accuracy in temperature regulation and the maintenance of a high level of humidity. Calculation of the analogue output is based upon the deviation between the ambient temperature and the setpoint value **[t1]**, and is comprised of two elements. The proportional element corresponds to the deviation multiplied by the proportional coefficient **[b2]**. The integration element increases progressively by a value which is proportional to the deviation, multiplied by the integration coefficient **[b3]** (%). See diagram below.

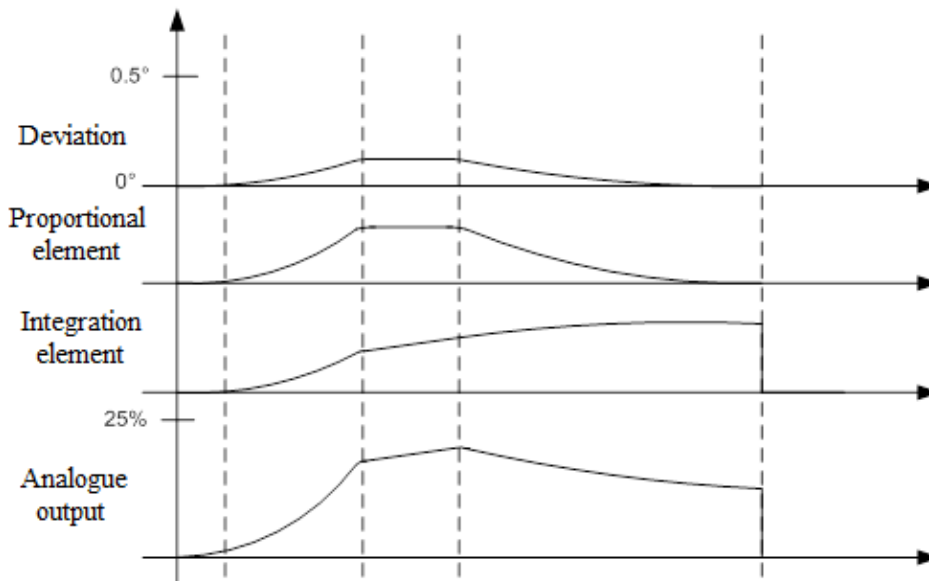

Figure 3.8.3

- 2 – Electronic expansion valve (modules DC24DE and DC24EE). In this mode, the analogue output regulates overheat by means of an electronic expansion valve, which is controlled by a 4-20 mA or 0-10 V output. See next chapter.

[b2]	Proportional coefficient for PI regulation (%) (Analogue Output Menu)
[b3]	Integration coefficient for PI regulation (%) (Analogue Output Menu)
[t1]	Setpoint (°C) (Ambient temperature menu)

3.9. ELECTRONIC EXPANSION VALVE (EEV)

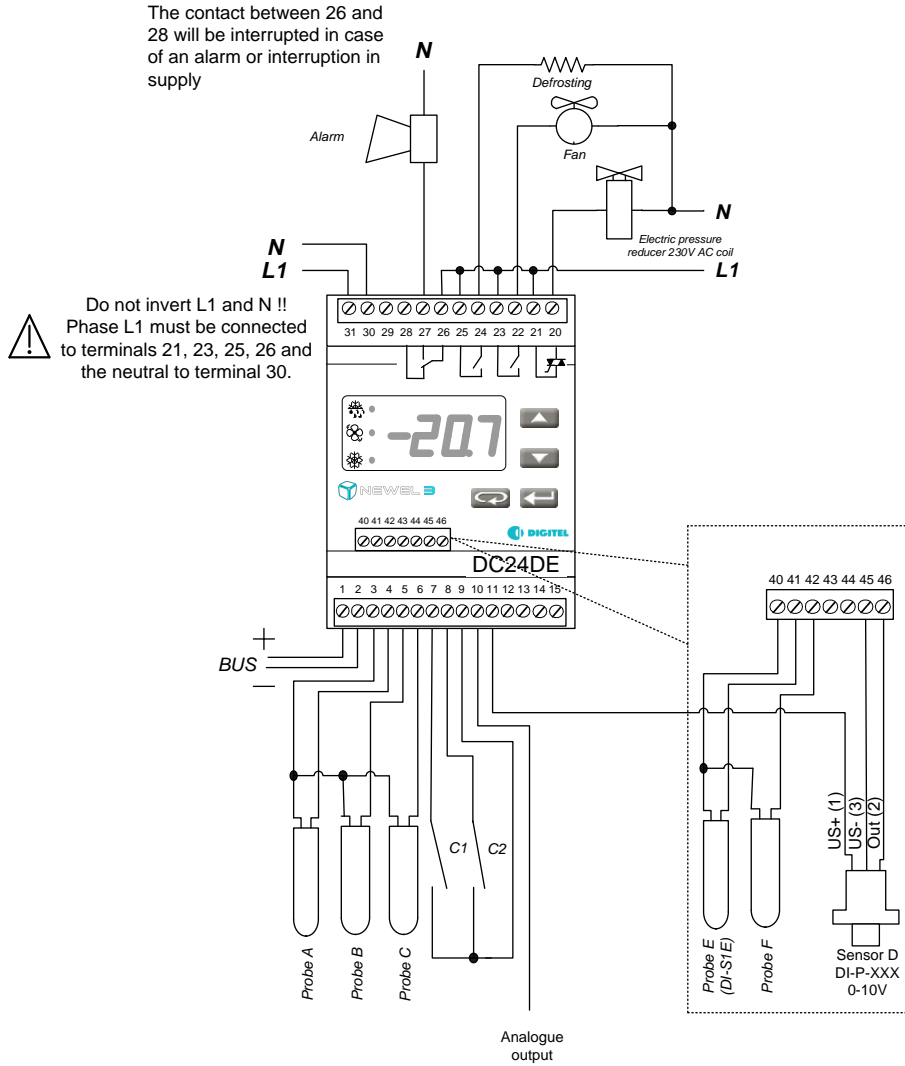

Figure 3.9.1

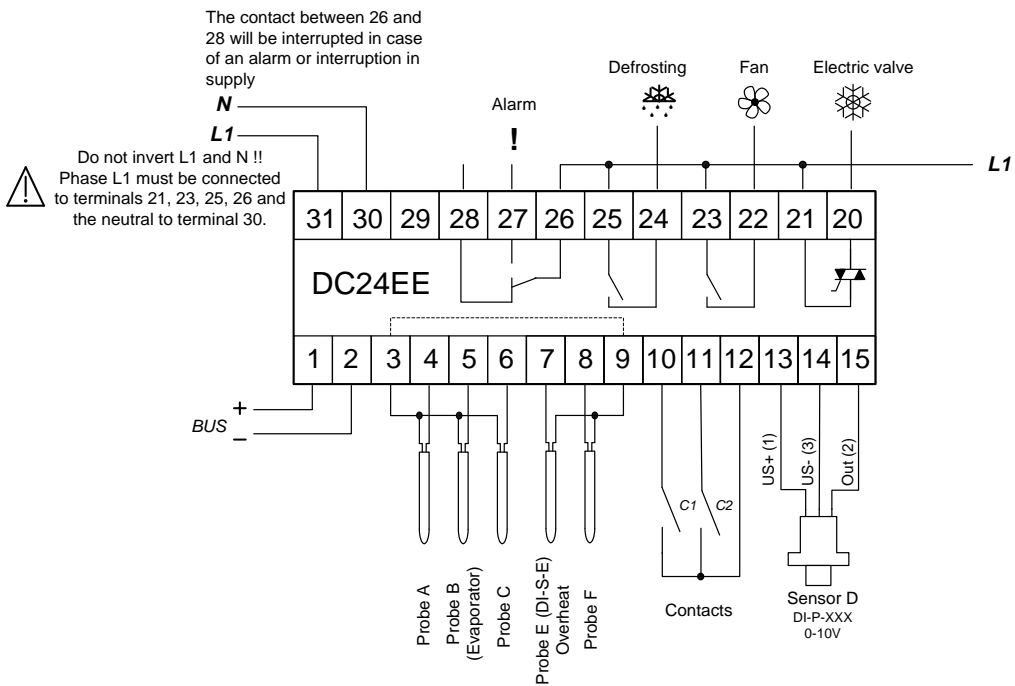

Figure 3.9.2

Modules DC24DE and DC24EE, in addition to all the other functions described in the previous paragraphs, will be responsible for the regulation of overheating by means of electronic expansion valves. These modules can be used for the management of pulse-operated expansion valves (regulation of pulse width) or expansion valves with progressive opening (e.g. using a step motor), controlled by a 4-20 mA or 0-10 V analogue signal. Overheat will be measured using a pressure sensor and a temperature probe (probe E) fitted to the evaporator output.

Parameter **[S1]** specifies the mode of operation of the expansion valve.

- 0 – self-adapting regulation. The module will attempt, insofar as possible, to maintain overheating within the limits programmed in parameters **[S2]** and **[S3]**. The regulation function is based upon a PID algorithm. Regulation is refined by the continuous analysis of the behaviour of the installation. After a number of hours of operation, information collected by this method can be used for the automatic optimization of internal regulation parameters. This optimization will proceed continuously, and will adapt these parameters to changes in operating conditions. The expansion valve will open when the temperature exceeds the neutral zone defined by parameters **[t1]** + **[t2]**.
- 1 – continuous self-adaptation. The expansion valve operates continuously. The regulator attempts to maintain the temperature in the centre of the neutral zone. The corresponding duration of opening is calculated by the observation of the behaviour of the unit concerned. In this mode, overheating will only be regulated as it approaches the lower limit **[S2]** programmed for the prevention of the return of fluid in the liquid state.

The type of refrigerant fluid will be programmed in parameter **[S4]**. The expansion valve will remain completely closed where the suction pressure exceeds the MOP limit programmed in **[S6]**.

In case of the regulation of a number of evaporators in close proximity, where the load loss between their outputs is negligible, the same pressure sensor may be used for the measurement of the suction pressure of a number of DC24 modules (up to a maximum of 8). Each evaporator will be equipped with a separate temperature probe. The arrangement of connections is described below.

[S1]	Overheat regulation (Overheat Menu)
[S2]	Minimum overheat setpoint (Overheat Menu)
[S3]	Maximum overheat setpoint (Overheat Menu)
[t1]	Setpoint (T. ambient menu)
[t2]	Delta (T. ambient menu)
[S4]	Refrigerant (Overheat Menu)
[S6]	MOP limit (maximum operating pressure) (Overheat Menu)

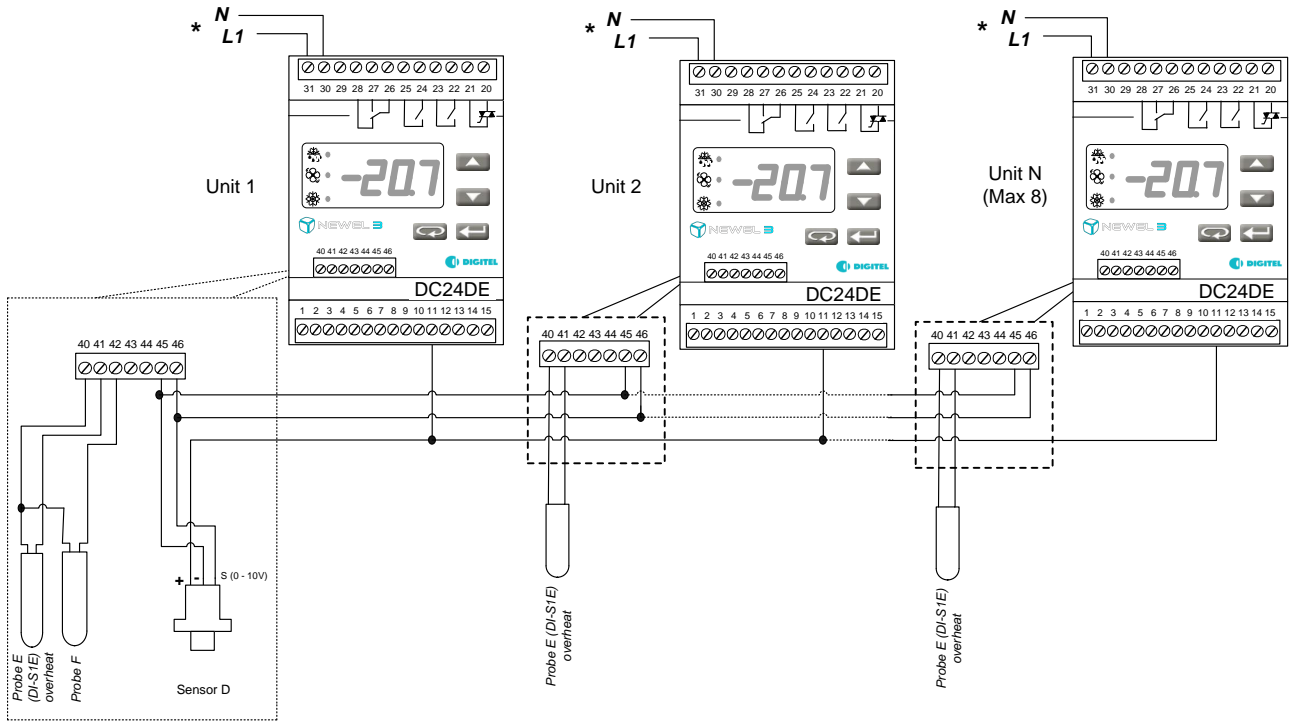

*  Do not invert L1 and N !!
Phase L1 must be connected to terminals
21, 23, 25, 26 and the neutral to terminal 30.

Figure 3.9.3



*  Do not invert L1 and N !!
Phase L1 must be connected to terminals
21, 23, 25, 26 and the neutral to terminal 30.

Figure 3.9.4

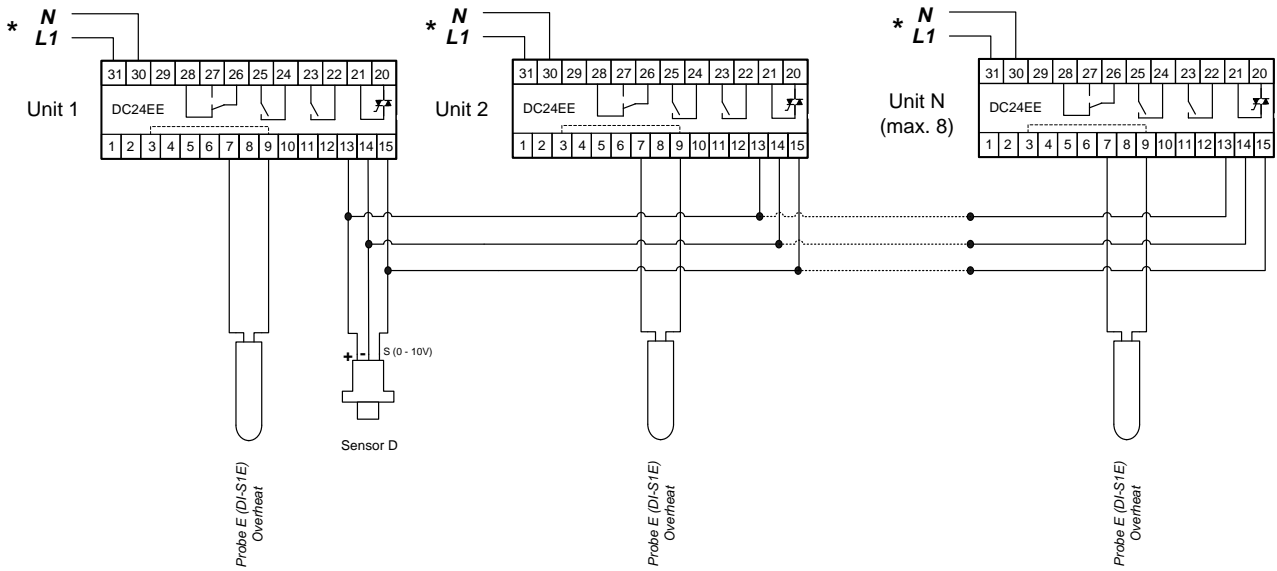
For larger capacity ratings, the use of progressive expansion valves is recommended. These may be controlled by analogue outputs, in accordance with the circuit layout described below.

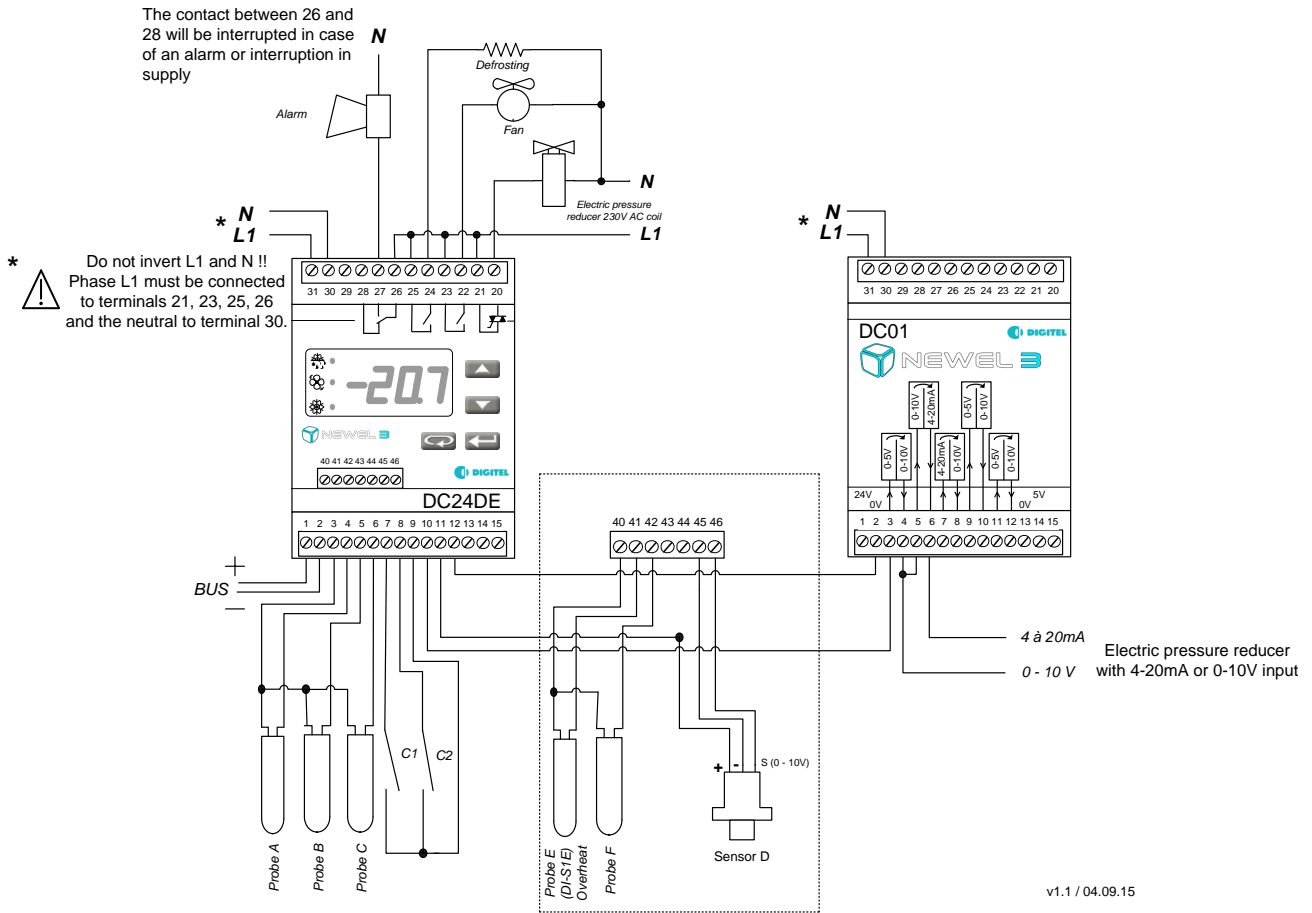

Figure 3.9.5

Expansion valves of various different types may be used with DC24DE and DC24EE modules. Contact your dealer for further details.

3.10. DC34D - PROGRESSIVE SUPERHEAT REGULATOR (STEPPER MOTOR)

The DC34D module is designed to manage a cooling unit equipped with a progressive electronic expansion valve with a bipolar stepper motor. It is directly compatible with the E2V and CCMT series expansion valves.

The connections are made according to the diagrams below.

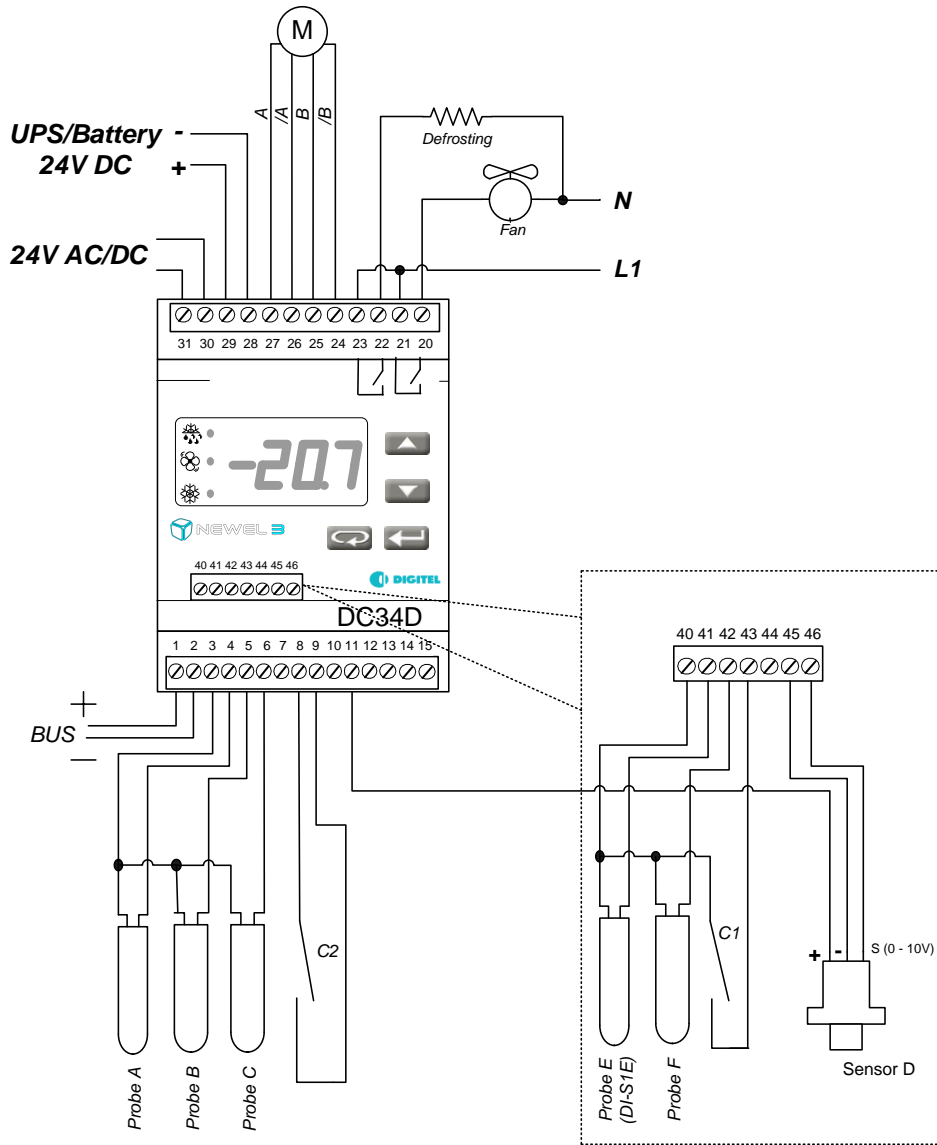

Figure 3.10.1 DC34D

For E2V valves:

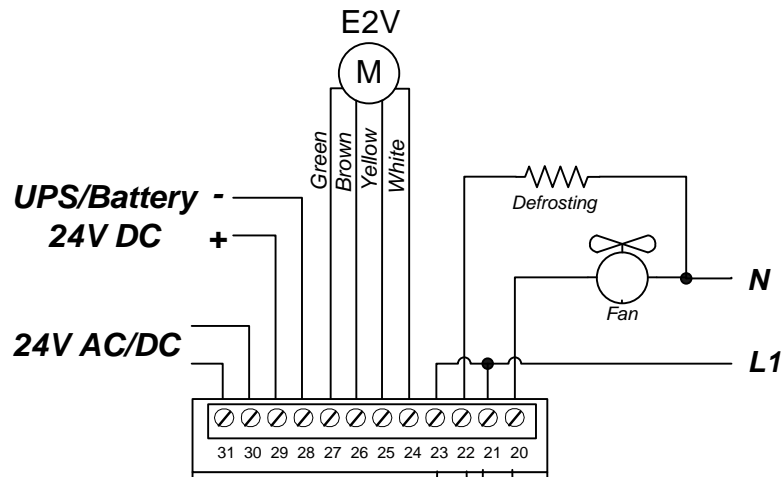

Figure 3.10.2 DC34D E2V

For CCMTXX valves:

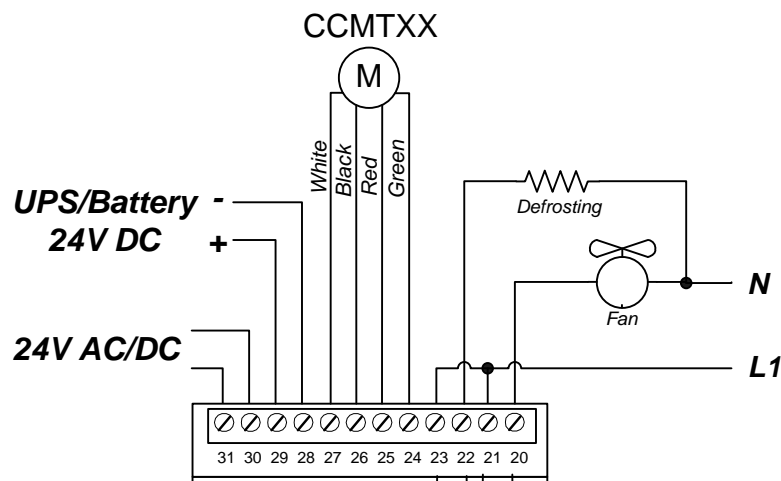

Figure 3.10.3 DC34D CCMT4

The UPS/Battery power supply is necessary to ensure the closure of the valve in case of a 24V AC/DC power failure. Its capacity and power must be sufficient to guarantee the complete closing of the valve from the state of being completely open. This will depend on the type of valve used. Similarly, the power of the main power supply must be calculated to cover the phase current of the valve used and the power supply of the DC34D module. The latter is approximately 7W.

The module manages all the functions of a cooling unit such as the DC24DE/EE modules configured for operating mode 0.

The parameters, with a few exceptions, are identical. The way they are programmed is also identical. The parameters for the analog output and those for the alarm output do not exist because these outputs are not available.

Only operating mode 0 (cooling unit) is implemented.

Parameter **[S11]** is used to select the valve type between:

0. generic
1. E2V
2. CCMT2/4/8
3. CCMT16/24
4. CCMT30/42

The value 0 (generic) is used to configure other types of valves that are not listed above. In this case, the following parameters must be entered in order to adapt the operation of the module to the characteristics of the valve used.

- Number of motor steps
- Speed (mS/step). Corresponds to $1000/(\text{number of steps per second})$.
- Phase current (mA)
- Holding current (mA)

These four parameters are not accessible with the buttons on the DC34D. They must be programmed with TelesWin.



The regulator type and the above parameters must be programmed before connecting the valve. Incorrect values can damage the valve!

When parameter **[F9]** - "**Special configuration**" is set to 1, the module no longer functions as a cooling unit controller. It only controls the stepper motor proportionally to the 4-20mA signal (terminal 13) or 0-10V (terminal 46). Parameter **[F10]** - "**Motor controlled by**" specifies which of these 2 inputs is used to control the motor. Value 1 corresponds to the 4-20mA signal, value 2 to 0-10V. Parameter **[S5]** is used to shift the position of the motor with respect to the analog signal that drives it. This offset can be positive or negative and is expressed in % of maximum opening.

3.11. INTERACT TYPE MANAGEMENT

A conventional refrigeration circuit is managed by a compressor plant regulation and a number of regulations for cooling units. These regulation functions are completely independent, and take no mutual account of each other. Refrigeration demand in the various units will be random and unforeseeable. The compressor plant regulation will not be aware of the number of units in service and the actual load demand.

The most rudimentary systems will only respond where the pressure exceeds consecutive and pre-set thresholds.

More advanced regulation functions (e.g. of the PID type incorporated in NEWEL3) will observe trends for pressure variation, and will attempt to act in anticipation by switching on or off compressors before the pressure deviates too far from the set point value. Although these regulation functions are more effective, in the absence of accurate information on events proceeding on the cooling unit side, they cannot deliver optimum management.

On the basis of this observation, Digitel has developed a regulation function which considers the entire installation, based upon ***interaction between the modules responsible for the management of cooling units and the module which controls the compressor plant***. This system is described as **INTERACT**. The program which manages this function is complex. A detailed description of its operation would substantially exceed the scope of this manual. A selection of the functions which will ensure the optimum management of the installation is set out below.

- The software considers the cooling unit and the compressor plant as two elements of a closely-linked combination. Conventional regulation systems regulate pressure by the start-up and tripping of compressors. The **INTERACT** system optimizes this regulation function by also acting on the cooling units.
- Where the suction pressure drops and falls below the set point value, rather than interrupting the supply to one of the compressors, the software will identify a cooling unit, the temperature of which is relatively close to the start-up limit. The software will start-up the unit concerned before this limit is achieved, in order to restore the pressure.
- Where the pressure rises, the software will attempt to identify a unit, the temperature of which is already acceptable, and will trip this unit if required, rather than starting up an additional compressor.
- The regulation system will undertake the continuous calculation of the capacity demand of all the cooling units, and will compare this value to the capacity delivered by the compressor plant. In the same way as the movement in pressure, the result of this comparison will contribute to the decision on the response to be adopted.
- Where a given unit of low capacity, in relation to the capacity of a compressor, generates demand for refrigeration at a time when the supply to all the remaining units is interrupted, the software will automatically associate this unit with another unit, which may already be put in service. If the software cannot identify any such unit, it will delay the start-up of the unit of low capacity.

The three diagrams below show a schematic representation of the INTERACT principle, in comparison with conventional regulations. The installation concerned comprises 4 cooling units, supplied by a two-compressor plant.

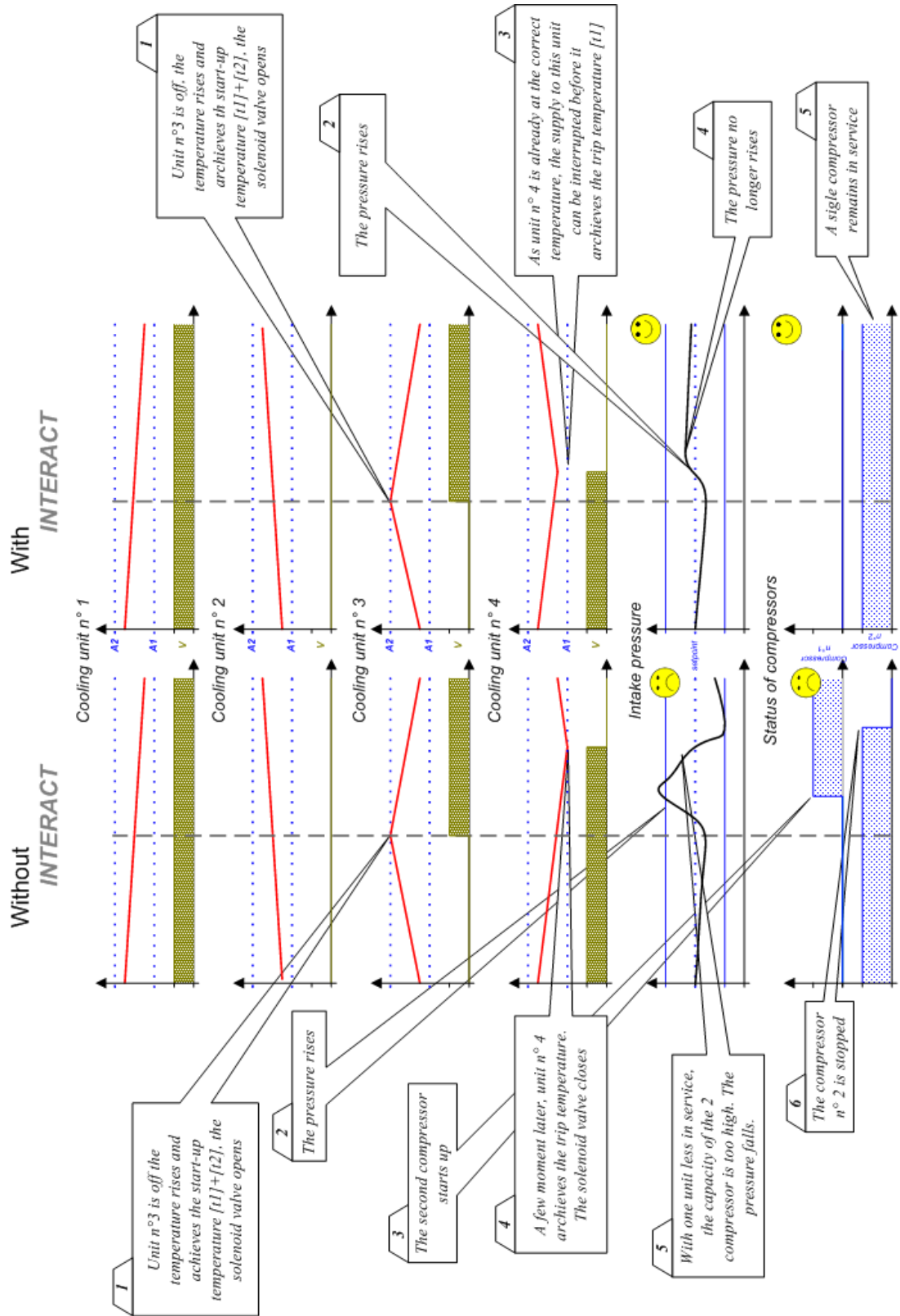

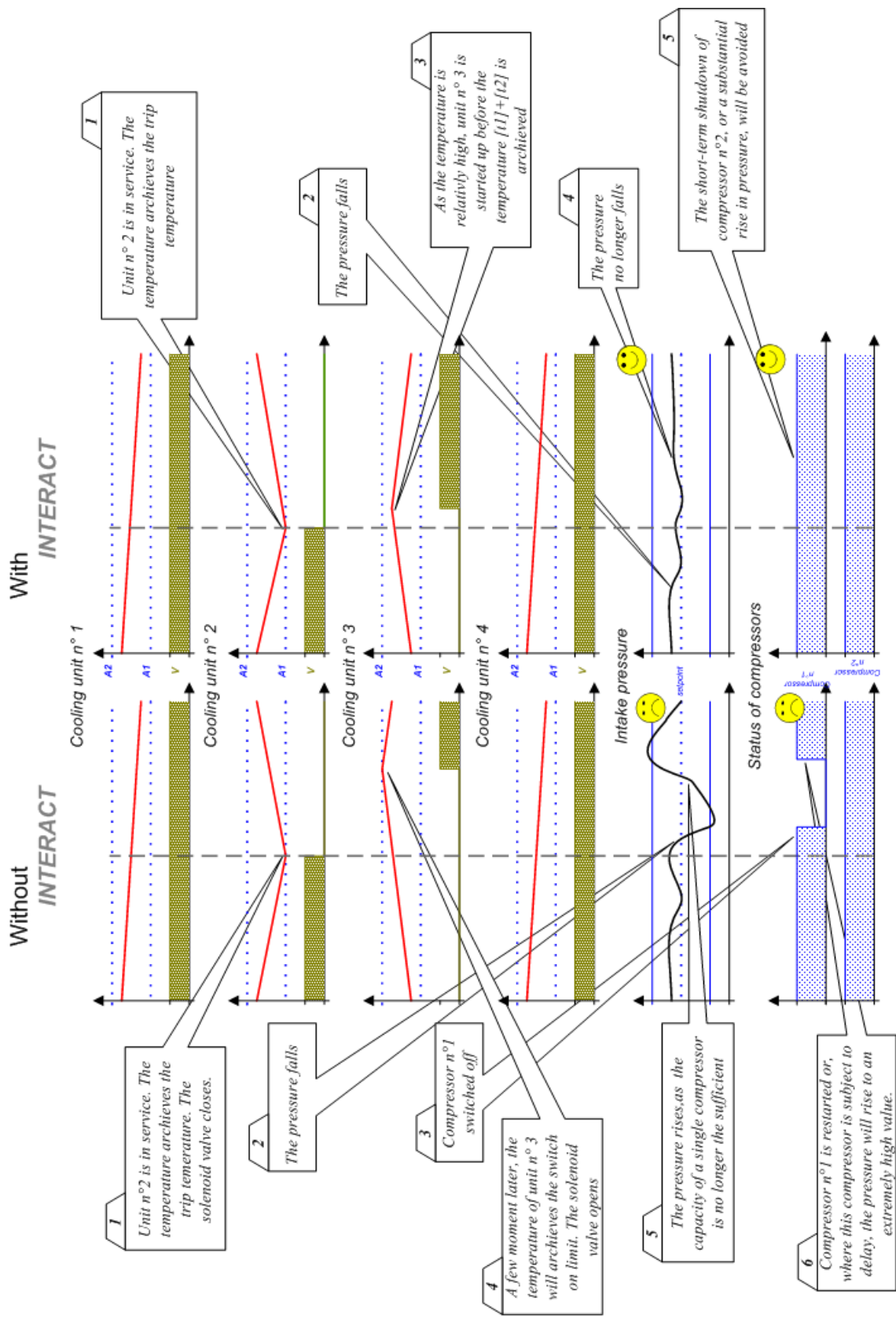

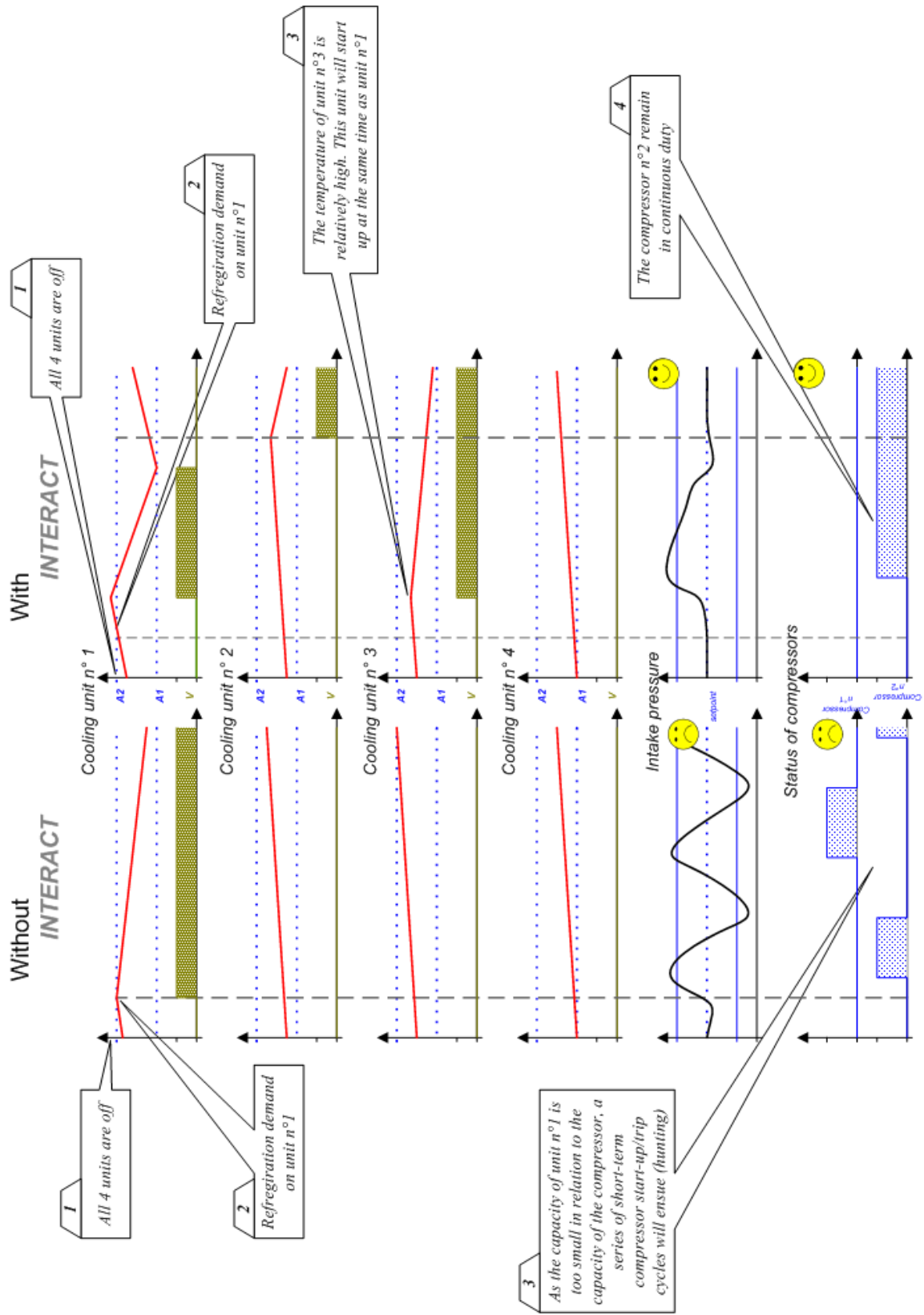

The **INTERACT** system represents a genuine advance in regulation technology for refrigeration installations.

The accuracy and stability of suction pressure regulation is significantly superior.

- Energy savings of the order of 10 – 15% may be achieved. This is due to a significant improvement in the regulation of suction pressure, which has the following consequences:
 - The efficiency of the compressor plants is improved. In practice, by the start-up of an additional cooling unit, the operation of compressors at an excessively low pressure, which will compromise their efficiency, can be avoided,
 - By eliminating periods of low pressure, excessively low evaporation temperatures, resulting in the excessive frosting of evaporators, can be avoided. The energy required for defrosting will be reduced accordingly.
- By avoiding excessively low evaporation temperatures, the dehumidification of units will be reduced, thereby improving the quality of refrigerated products.
- The service time and rest time of compressors will be extended in a spectacular fashion. Their service life will be increased accordingly. Network disturbances caused by frequent switching operations will be reduced.
- In many cases, the optimization of regulation will allow the number of compressors to be reduced, by the use of compressors of higher capacity. This is associated with a radical reduction in the cost of the compressor plant.

Parameter **[L3]** indicates the capacity of the evaporator in kVA for cooling units, or the total capacity of compressors for the module which manages the compressor plant.

The installation must be equipped with a DC58 remote monitoring unit.

3.12. RESCUE PROGRAM

Over a number of days, the satellite unit will calculate the average opening time of the valve and the average rest time between two successive openings. Where a fault on the ambient probe is detected, the device will take no further account of information delivered by this probe, and will control the valve using the clock function. The valve will be opened for a time interval which is equal to the average opening time calculated previously, and will close for a time interval equal to the average rest time, etc. This will allow the temperature to be maintained at a level which is close to the setpoint value, provided that there has been no significant change in operating conditions on the installation. The alarm contact will be active throughout the duration of the rescue program.

Where communication with the DC58 central unit is interrupted (due to an interruption in supply, loss of the bus connection or loss of the DC58 central unit), the satellite units will continue to operate and deliver their associated functions.

3.13. PROBES CALIBRATION

It is possible to set a correction for each temperature probe used, in parameters **[r5]**, **[r6]** and **[r7]**. A negative value will reduce the value displayed, while a positive value will increase the value displayed.

[L3]	Capacity of evaporator (Interact Menu)
[r5]	Correction of ambient temperature probe (Settings Menu)
[r6]	Correction of defrosting probe (Settings Menu)
[r7]	Correction of probe C (Settings Menu)

3.14. SETPOINT OFFSET

The setpoint temperature determined by values for parameters **[t1]** and **[t2]** may be temporarily offset by a positive or negative value, which is programmable in parameter **[t8]**. This offset will be controlled by the clock function of the module, within the time interval programmed using parameters **[t9]** and **[t10]**.

The same setpoint offset may be controlled by the closure of contacts C1 or C2, where the function of these contacts is programmed for **setpoint offset [F1=4 or F4=4]**.

If parameter **[t13]** is programmed on “1” the alarm limits of ambient temperatures (**[t5]** and **[t6]**) are offset together with the same value than the setpoint. With **[t13]** on “0” those limits are fixed. The same way, for **[C6=1]** the alarm limits of probe C are offset together with the setpoint. The alarm limits of the other probes are not offset.

3.15. WEEKLY SCHEDULE

This option will only be available with central unit DC58

This option provides scope for the modification of the satellite unit during periods of reduced activity, in accordance with a weekly schedule which is entered in the DC58 central monitoring unit (for example, hours of closure of supermarkets). Depending upon the programming of parameters in the “Schedule” menu during periods of closure, the satellite unit may shut down the unit concerned or offset the temperature setpoint.

The latter operation will be combined with any daily offset scheduled between **[t9]** and **[t10]**.

The standard output for the control of an alarm device may be used for the control of lighting. To this end, the **Alarm output function** in the *Schedule (TelesWin)* menu will be programmed to “**lighting control**”. With an auxiliary relay connected to this output, it will be possible to control the lighting and closure of the night blind of a refrigeration unit – see [Figure 3.15.1](#) and [Figure 3.15.2](#). The **Weekly schedule function?** in the *Schedule (TelesWin)* menu of the DC58 central unit must be programmed to “**yes**”.

[F1]	Function of contact C1 (C1, C2 Contact Menu)
[F4]	Function of contact C2 (C1, C2 Contact Menu)
[t1]	Setpoint (T. ambient menu)
[t2]	Delta (T. ambient menu)
[t5]	Lower alarm limit (T. ambient menu)
[t6]	Upper alarm limit (T. ambient menu)
[t8]	Setpoint offset (T. ambient menu)
[t9]	Start of setpoint offset (T. ambient menu)
[t10]	End of setpoint offset (T. ambient menu)

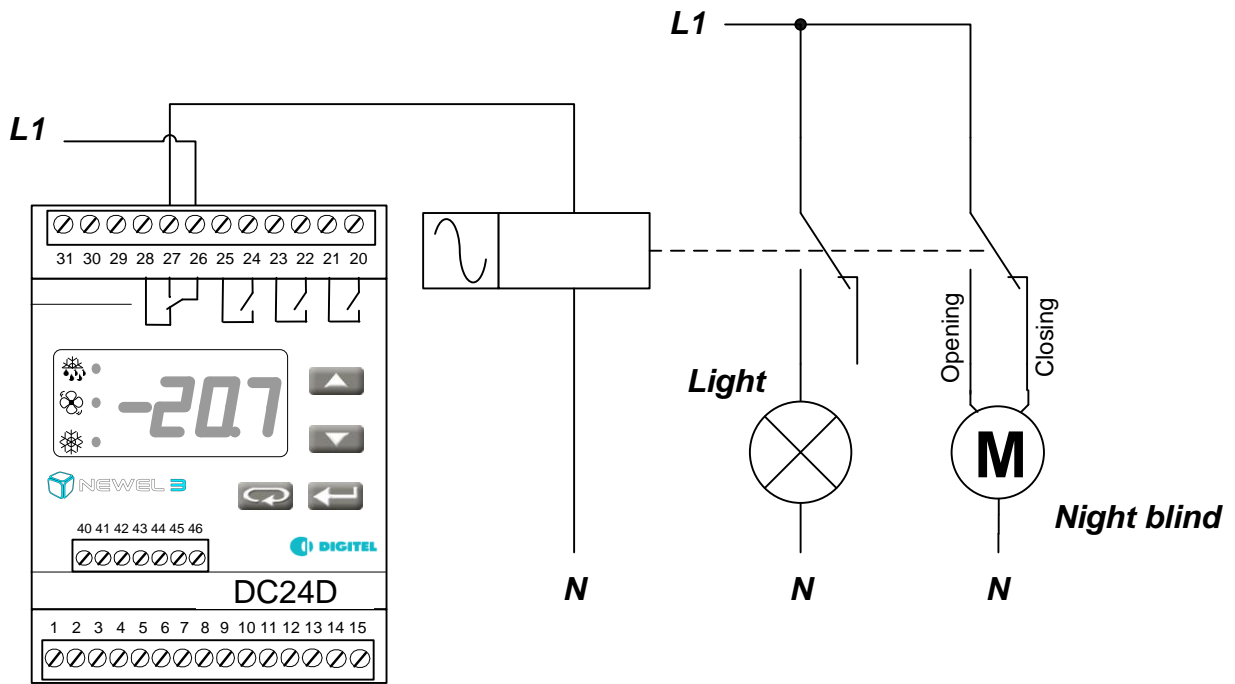

Figure 3.15.1

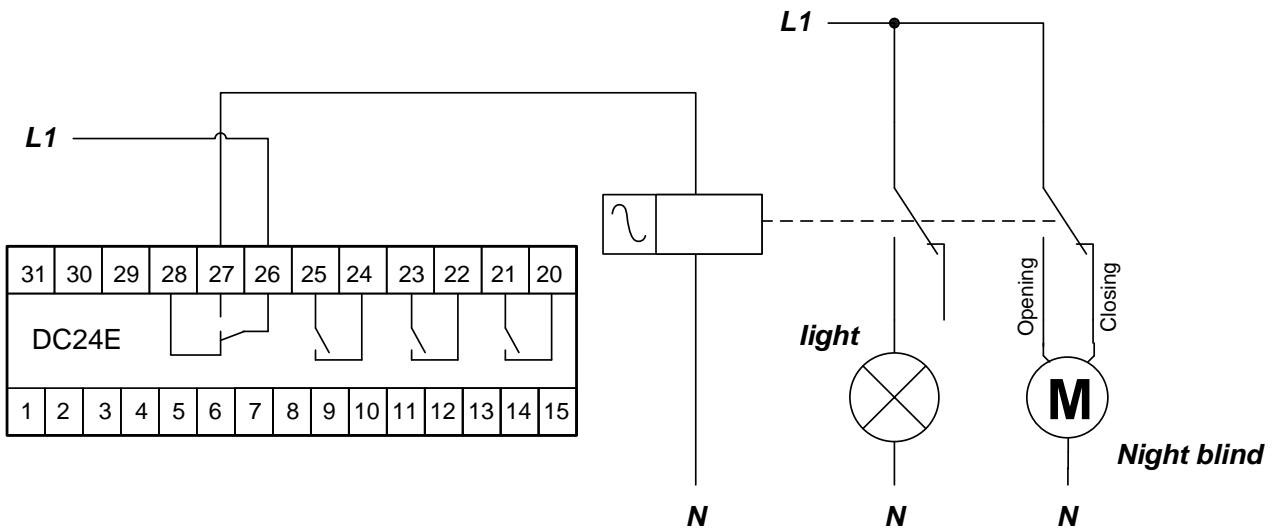

Figure 3.15.2

3.16. PARAMETERS

Basic configuration

Sym.	Lvl.	Function	comment.	Default value	Value applied
PAS	0	Password		0	
r1	3	Mode of operation <i>0 = cooling unit 1 = Management of compressors 2 = Universal regulation 3 = Monitoring 4 = Management of evaporators 2, 3, etc.</i>		0	
r20	3	Type of regulation <i>0 = negative unit 1 = positive unit</i>	r1 = 0	0	
AD	3	Module's address <i>Don't change it when the modul is connected to the central unit DI58/DC58</i>			

Parameters

Sym.	Lvl.	Function	comment.	Default value	Value applied
PAS	0	Password		0	
Ambient temperature	t1	1	Setpoint (°C)	1	
	t2	2	Delta (°C). The device regulates between the temperatures t1 and t1+t2	1.0	
	t3	3	Limitation of the lowest setpoint (°C)	-90	
	t4	3	Limitation of the highest setpoint (°C)	90	
	t13	2	Alarm limit for Probe A <i>0 = absolute value 1 = relative to setpoint</i>	0	
	t5	2	Lower alarm limit (°C)	0	
	t6	2	Upper alarm limit (°C)	10	
	t7	2	Alarm delay (min)	30.0	
	t8	2	Setpoint offset (°C)	0.0	
	t9	2	Start of setpoint offset (HH:M)	0.0	
	t10	2	End of setpoint offset (HH:M)	0.0	
	t11	3	Minimum operating time (min)	0.0	
t12	3	Minimum rest time (min)	0.0		

Overheat (DC24DE, DC24EE and DC34D)	S0	2	Electronic expansion valve? <i>0 = No 1 = Yes</i> <i>For DC34D the parameter is hidden and always set to 1 / Yes.</i>		0	
	S1	3	Overheat regulation <i>0 = self-adaptation 1 = continuous self-adaptation</i>		0	
	S2	3	Minimum overheat setpoint (°C)		5.0	
	S3	3	Maximum overheat setpoint (°C)		8.0	
	S4	3	Refrigerant <i>1 = R12 2 = R22 3 = R134A 4 = R502 5 = R500</i> <i>6 = MP39 7 = HP80 8 = R404A 9 = R717 (NH3) 10 = Frozen water</i> <i>11 = R407 (Fluid) 12 = R407 (gas/fluid) 13 = R23</i> <i>14 = R413A (ISCEON 49) 15 = R417A (ISCEON59) 16 = R422A (ISCEON79)</i> <i>17 = R507 18 = R744 (CO2) 19=R723 20 = PerformaxLT_ST 21 = R290</i> <i>22 = tConvR407A_Fluid 23 = tConvR407A_Gas</i> <i>version 17421 onwards: 24 = R448A 25 = R449A 26 = R450A(N13)</i> <i>version 19301 onwards: 27 = R513A 28 = R452A</i> <i>version 20471 onwards: 29= RS-51</i>		8	
	S5	3	Correction of measurement (slide (positive) + loss of load (negative)) (°C)		0.0	
	S6	3	MOP limit (maximum operating pressure) (°C)		40.0	
	S7	3	Minimum opening of expansion valve (%)		0	
	S8	3	Maximum opening of expansion valve (%)		100	
S9	3	Range of measurement of pressure sensor – lower limit (bar)		-1		

S10	3	Range of measurement of pressure sensor – upper limit (bar)		7	
S11	3	Only for DC34D: Electronic expansion valve type. 0-unknown, 1-E2V, 2-CCMT2/4/8, 3-CCMT16/24, 4-CCMT30/42		1	

Defrosting	d1	3	Is Probe B present? 0 = no 1 = Yes		0	
	d2	2	Type of defrosting <i>0 = electrical 1 = air-assisted, with fan 2 = air-assisted, without fan 3 = economy 4 = with clock function 5 = heating for air conditioning 6 = gas-assisted</i>		1	
	d3	2	Delay of compressor/solenoid valve after defrosting (min)		0.0	
	d4	2	Start-up time of fan after defrosting	d1 = 1	0.0	
			Start-up delay of fan after defrosting (min)	d1 = 0	0.0	
			Neutral zone for heating/cooling	d2 = 5	0.0	
	d5	2	End of defrosting temperature (°C)	d1 = 1	5.0	
			Delta – heating (°C)	d2 = 5	5.0	
	d6	2	Maximum duration of defrosting (min)		30.0	
	d7	2	<i>0 = deactivated 1-999 = if the total start-up time of the compressor/solenoid valve since the most recent defrosting is shorter than this value, the next defrosting operation will be ignored</i>		0	
	d8	2	Start of defrosting no. 1 (HH:M)		0.0	
	d9	2	Start of defrosting no. 2 (HH:M)		6.0	
	d10	2	Start of defrosting no. 3 (HH:M)		12.0	
	d11	2	Start of defrosting no. 4 (HH:M)		18.0	
	d12	2	Start of defrosting no. 5 (HH:M)		0.0	
	d13	2	Start of defrosting no. 6 (HH:M)		0.0	
	d14	2	Lower limit on evaporator alarm temperature (°C)		-45	
	d15	2	Upper limit on evaporator alarm temperature (°C)		15.0	
	d16	2	Alarm delay (min)		30.0	
d17	2	Zonal defrosting controlled by the central unit 0 = deactivated 1 = activated		0.0		
d18	2	Number of defrosting zone (0 – 31)	d17 = 1	255.0		
d19	2	Await end of other defrosting operations in the zone 0 = deactivated 1 = activated	d17 = 1	255.0		

Fans	U1	2	Operation of fan <i>0 = tripped during defrosting 1 = permanently in service 2 = controlled with valve 3 = controlled with evaporator probe</i>		0	
	U2	2	Start-up temperature of fan (°C)	U1 = 3	-15	
	U3	2	Trip temperature of fan (°C)	U1 = 3	-10	

analogue Output	b1	3	Operation of analogue output <i>0 = proportional to ambient temp. 2 = electronic expansion valve 1 = PID regulation of ambient temp. (modification only with TelesWin)</i>		0	
	b2	2	Analogue output – temperature corresponding to 0% (°C)	b1 = 0	-25	
			Proportional coefficient for PI regulation (%)	b1 = 1	20	
b3	2	Analogue output – temperature corresponding to 100% (°C) Integration coefficient for PI regulation (%)	b1 = 0 b1 = 1	-15 20		

Probe C	C1	3	Is probe C present? 0 = no, 1 = yes		0	
	C2	2	Lower alarm limit (°C)	C1 = 1	0.0	
	C3	2	Upper alarm limit (°C)	C1 = 1	10.0	
	C4	2	Alarm delay (min)	C1 = 1	30.0	
	C5	2	Significance of probe C in the estimation of the product temp. (%)	C1 = 1	0	

	C6	2	Alarm limit for Probe C 0 = absolute value 1 = relative to setpoint	C1 = 1	0

	L3	2	Capacity of evaporator (KVA)		5.0
--	----	---	------------------------------	--	-----

Probe E	E1	3	Is probe E present? 0 = no, 1 = yes		0
	E2	2	Lower alarm limit probe E (°C)		0.0
	E3	2	Upper alarm limit probe E (°C)		10.0
	E4	2	Alarm delay probe E (min)		30.0
Probe F	E5	2	Is probe F present? 0 = no, 1 = yes		0
	E6	2	Lower alarm limit probe F (°C)		0.0
	E7	2	Upper alarm limit probe F (°C)		10.0
	E8	2	Alarm delay probe F (min)		30.0
	E9	2	Probe F is a 0 = real, 1 = virtual probe		0

Contacts C1, C2	F1	3	Function of contact C1 <i>0 = alarm upon closure 1 = alarm upon opening 2 = shutdown of unit upon closure 3 = none 4 = setpoint offset upon closure 5 = door contact 7 shutdown of unit upon opening</i>		5
	F2	2	Alarm delay on contact C1 (min)	F1 = 0, 1, 5	5.0
	F3	2	<i>0 = deactivated 1 – 99.9 = delay to start-up of compressor/solenoid valve after door closure</i>	F1 = 5	0.5
	F4	3	Function of contact C2 <i>0 = alarm upon closure 1 = alarm upon opening 2 = shutdown of unit upon closure 3 = none 4 = setpoint offset upon closure 5 = defrosting pulse 6 = monitoring of defrosting on supplementary evaporators 7 = shutdown of unit upon opening</i>		0
	F5	2	Alarm delay on contact C2 (min)	F4 = 0 ou 1	30.0
	F6	2	Function of Alarm output <i>0 = alarm output 1=command of light 3= command of light with contact C1</i>		
	F7	2	Delay of light extinction		
	F8	2	Alarm output <i>0 = only ambient temperature 1 = all alarms</i>		
	F9	2	Special configuration <i>0 = none 1 = alarm output controls defrost of evap. Nr. 2 2 = Fan output controls deforst of evap. Nr. 3 4 = Monitoring CO2 concentration 5 = Monitoring gas concentration</i>		0
	F10	2	Warning limit high CO2 concentration (%)	F9 = 4 or 5	3
	F11	2	Warning limit too high CO2 concentration (%)	F9 = 4 or 5	6

Miscellaneous settings	r2	2	Value displayed in normal operation <i>0 = probe A 1 = probe B 2 = probe C 3 = product temperature 5 = time (DI24DE and DI24EE only) 6 = pressure 7 = overheat 8 = opening of expansion valve</i>		0
	r3	2	Display during defrosting <i>0 = probe A 1 = probe B 3 = product temperature 4 = "dEG" message</i>		0
	r4	2	Special functions <i>0 = normal operation 1 = complete shutdown 2 = override operation 3 = override defrost</i>		0
	r5	2	Correction of ambient temperature probe (°C)		0.0
	r6	2	Correction of evaporator probe (°C)		0.0
	r7	2	Correction of probe C (°C)		0.0
	r8	3	Level 1 password (user)		0.0
	r9	3	Level 2 password (operating engineer)		0.0

r10	3	Level 3 password (installer)		0.0	
r11	3	Language <i>0 = French 1 = English 2 = German 3 = Italian 4 = Spanish</i>		1	
r12	3	Temperature probe type <i>0=PT1000 -80..+80 1=PT1000 -100..+160 2=PT100 -80..+130 3=NTC -37..+100 4=PTC -55..+130)</i>		0	
r13	3	Correction of probe E (°C)		0	
r14	3	Correction of probe F (°C)		0	

Time, date	H1	1	Hour setting		10	
	H2	1	Minutes setting		25	
	H3	2	Day of the month setting		6	
	H4	2	Month setting		5	
	H5	2	Year setting		5	
	H6	2	Day of the week setting		4	

Alarm codes for the management of cooling units and the management of multiple evaporators

		<i>Codes des alarmes</i>	
Alarms	1	Excessively low ambient temperature	
	2	Excessively high ambient temperature	
	3	Excessively low evaporator temperature	
	4	Excessively high evaporator temperature	
	5	Excessively low probe C temperature	
	6	Excessively high probe C temperature	
	7	Excessively low probe E temperature	
	8	Excessively high probe E temperature	
	9	Excessively low probe F temperature	
	10	Excessively high probe F temperature	
	13	Alarm on contact C1	
	14	Alarm on contact C2	
	15	End of defrosting temperature not achieved	
	20	Fault on probe A	
	21	Fault on probe B	
	22	Fault on probe C	
23	Fault on suction pressure sensor		
24	Fault on probe E		
25	Fault on probe F		
26	Failure CO2 Sensor		
27	Warning – high CO2 concentration		
28	Alarm – too high CO2 concentration		